

Integrity - Service - Excellence

ESOH Management and Transformation in the Air Force



U.S. AIR FORCE

David Martin
HQ AFMC/A7CVO
Shared Functions Co-chair
EESOH-MIS

Enterprise Environmental, Safety, & Occupational Health Management Information System



- **Business Transformation**
- **Business Enterprise Architecture (BEA)**
- **Policy**
- **Old Business Practices**
- **New Business Practices**
- **Stewarded & Shared Data**
- **Process-centric Way Ahead**
- **Enabling the Mission!**



U.S. AIR FORCE

Business Transformation is Critical to DoD Success

“We simply have to transform this place. It is every bit as important to the success of the global war on terrorism as the other things we’re doing.”

-Secretary of Defense Donald Rumsfeld



“It's a key element in the secretary's efforts to transform this department.... transformation has been viewed as new weapons systems or communications, or even culture.... but there's another one, too, and that's transforming the way we do business in this place.”

-Under Secretary of Defense (Comptroller) Dov Zakheim



U.S. AIR FORCE

BEA 3.0 Construct and the Enterprise Transition Plan

The Big Picture

The Business Enterprise Priorities on the right address the top level responsibilities for the Department of Defense associated with each **Core Business Mission (CBM)** on the left.

DoD Core Business Missions (CBMs)

- Human Resources Management
- Weapon System Lifecycle Management
- Materiel Supply & Service Management
- Real Property & Installations Lifecycle Management
- Financial Management

Who are our people, what are their skills, where are they located?

Who are our industry partners, and what is the state of our relationship with them?

What assets are we providing to support the warfighter, and where are these assets deployed?

How are we investing our funds to best enable the warfighting mission?

DoD Business Enterprise Priorities (BEPs)

- Personnel Visibility
- Common Supplier Engagement
- Acquisition Visibility
- Materiel Visibility
- Real Property Accountability
- Financial Visibility

Required Integration



Integrity - Service - Excellence



ESOH is Cross-cutting

U.S. AIR FORCE

The Big Picture

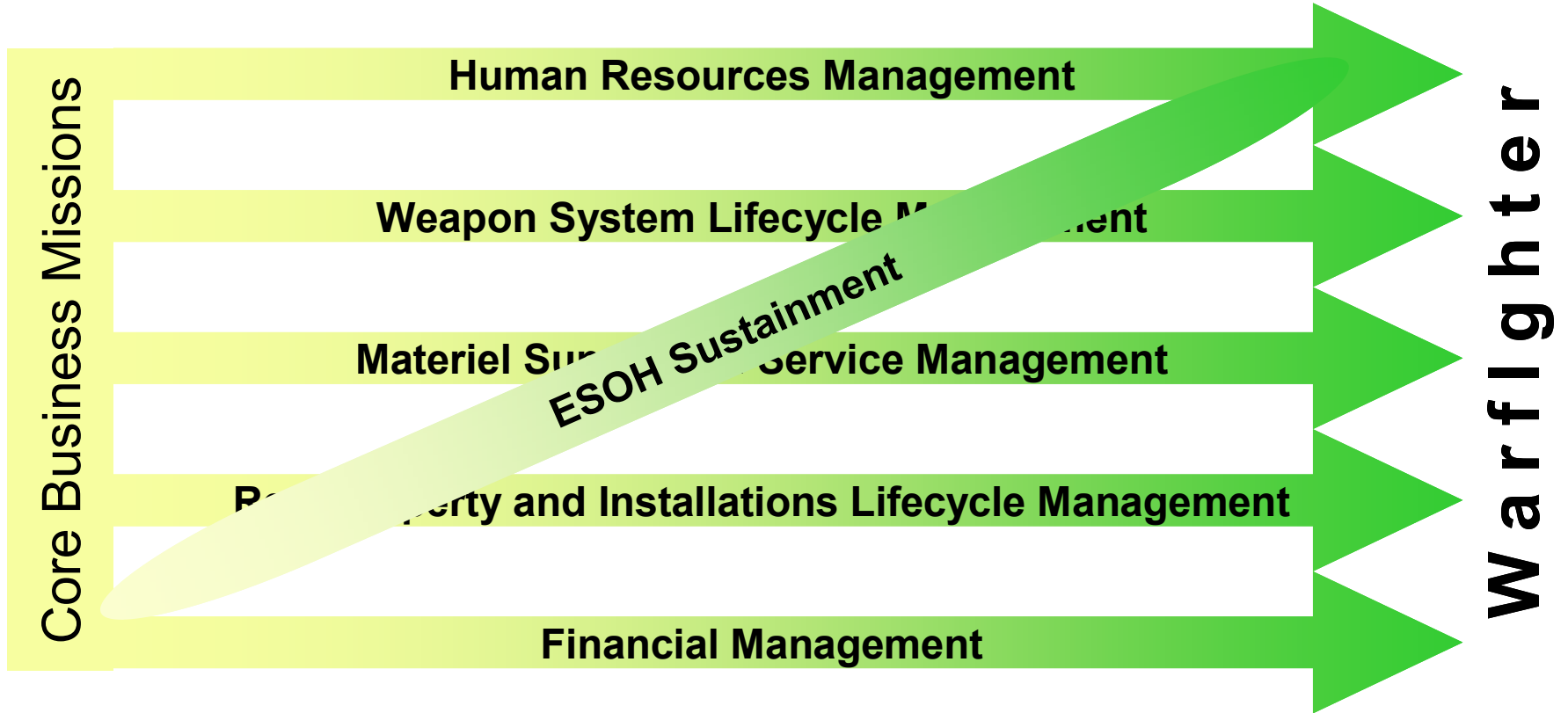

ESOH Transformation Cross Cuts ALL Core Business Mission Areas and Business Enterprise Priorities



U.S. AIR FORCE

Vision: Transforming Data Into Information To Knowledge

EESOH-MIS
And
ACES-EM

ESOH-MS
And
EMS

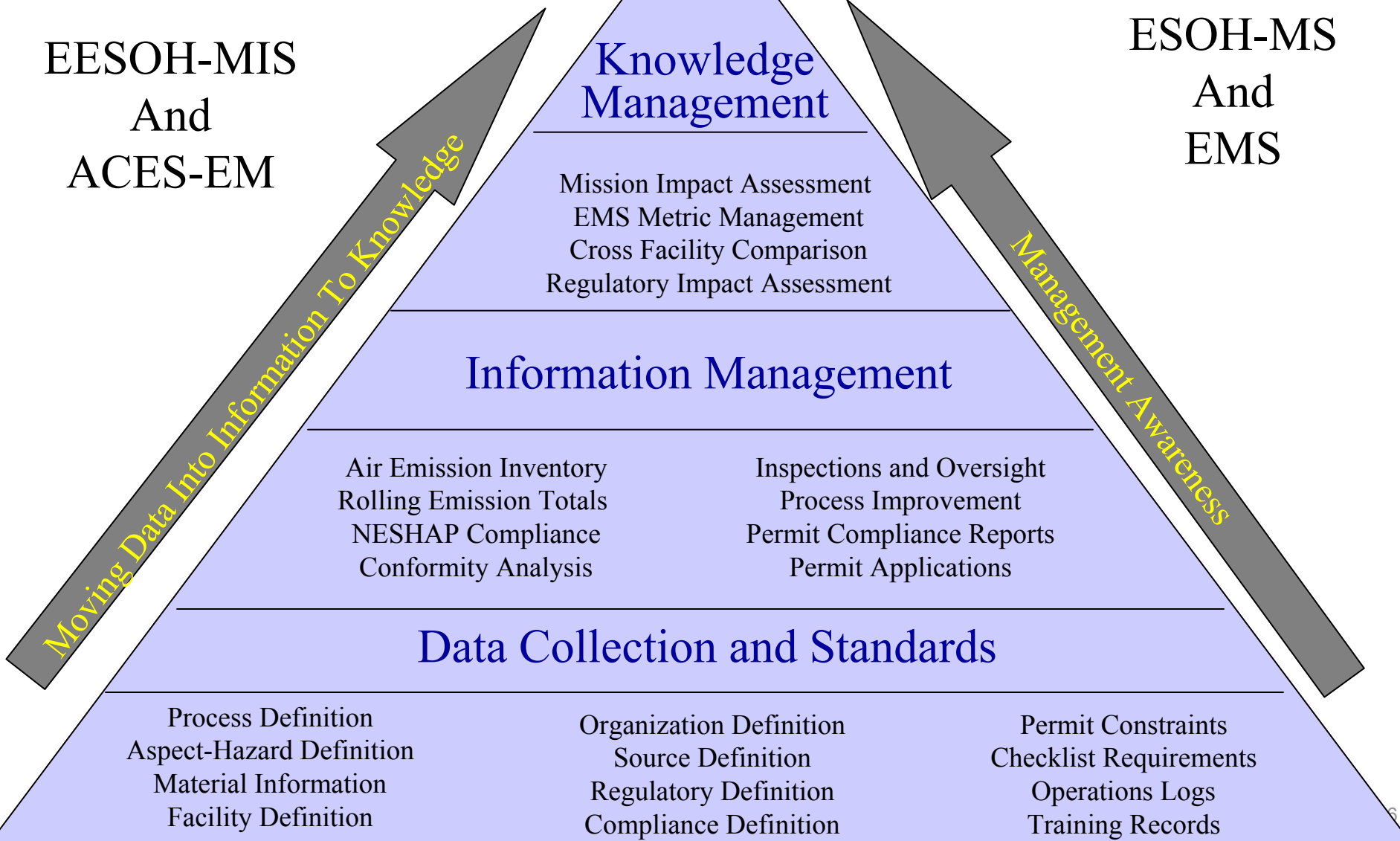

Knowledge Management

Mission Impact Assessment
EMS Metric Management
Cross Facility Comparison
Regulatory Impact Assessment

Information Management

Air Emission Inventory
Rolling Emission Totals
NESHAP Compliance
Conformity Analysis

Inspections and Oversight
Process Improvement
Permit Compliance Reports
Permit Applications

Data Collection and Standards

Process Definition
Aspect-Hazard Definition
Material Information
Facility Definition

Organization Definition
Source Definition
Regulatory Definition
Compliance Definition

Permit Constraints
Checklist Requirements
Operations Logs
Training Records



U.S. AIR FORCE

ESOH Transformation

Overarching AF Policy

■ Use of Commander 90 Series

- AFPD 90-8, ESOH
 - Establish Core Mission Area Executive Agent
- AFI 90-801, ESOH Councils
 - Establishes ESOH Councils at AF, MAJCOM, Base level(s)
- AFI 90-802 (Draft), ESOH Management System

■ Transforming Key Functional Series AFIs to 90 Series

- 48 – Occupational & Environmental Health Policy
- 32 – Environmental Policy
- 91 – Safety Policy



ESOH Transformation Strategy

- **ESOH Management System – not Environmental Management System**
 - **Integrate All Environmental Aspects & Impacts**
 - **Integrate All Safety and Health Hazards & Risk**
 - **Integrate via Common Processes “Units of Work”**
 - **Aspect = Hazard**
 - **Impact = Mishap**
 - **Significance = Risk**
- **Units of Work Drive ESOH Processes**
 - **Owned / Defined / Maintained by the People doing the work**
 - **Evaluated and controlled by the E, S, OH community**
 - **Regulatory constraints**
 - **Safety concerns**
 - **Exposure controls**
 - **Clear hazard communication from the worker to the commander**



ESOH Transformation Strategy

U.S. AIR FORCE

■ Where We Need to Be

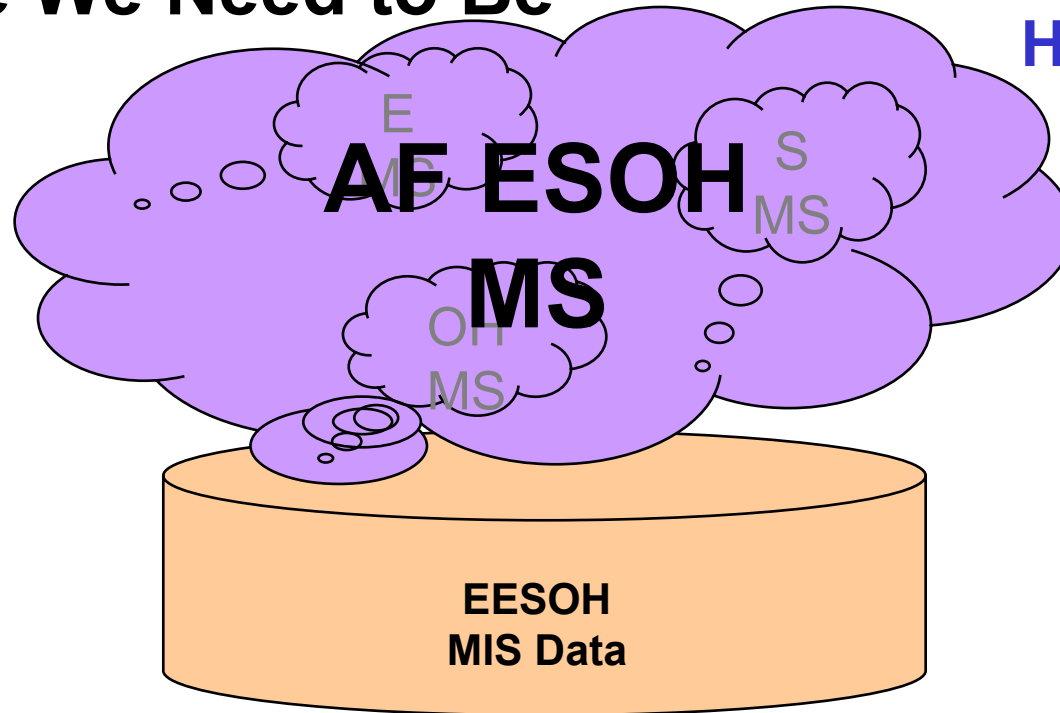

1 MS
Held Up By
1 MIS

- Saves Resources—MIS Funding Consolidated
- Captures E, S, OH Synergy—Shared Data
- Makes Sense to the Line CCs



U.S. AIR FORCE

Using The Authorization To Define Common Processes

SAME HAZARDOUS PROCESS - DIFFERENT PERSPECTIVES

Material Cost Schedule?

Perform Specification Cost?



Logistics



Quality

Exams Restrictions Impact?

Facility Hazards Controls?

Hazards PPE Controls Risk?

Accidents Hazards Risks?

HazMat Waste Emissions Resources Permits?



Doc



CE



Occ Health

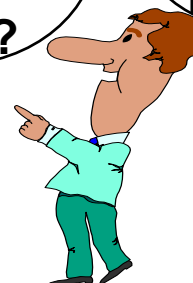

Safety



Environmental



EESOH-MIS

U.S. AIR FORCE

AF-EMIS

Shop



HazMat
Authorizations

AFSAS

Shop



Mishaps
Findings

CCS

Shop



Exposure Groups
Processes
Hazmat
Consumption for
Air Emission
(APIMS)



EESOH-MIS

U.S. AIR FORCE

AF-EMIS



Shop
HazMat
Authorizations



AFSAS



Shops
Mishaps
Findings



CCS



Shop
Exposure Groups
Processes
Hazmat
Consumption for
Air Emission
(APIMS)

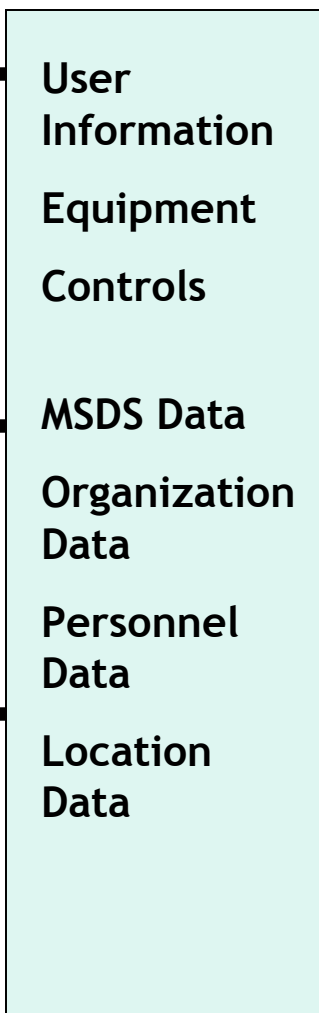



EESOH-MIS

U.S. AIR FORCE

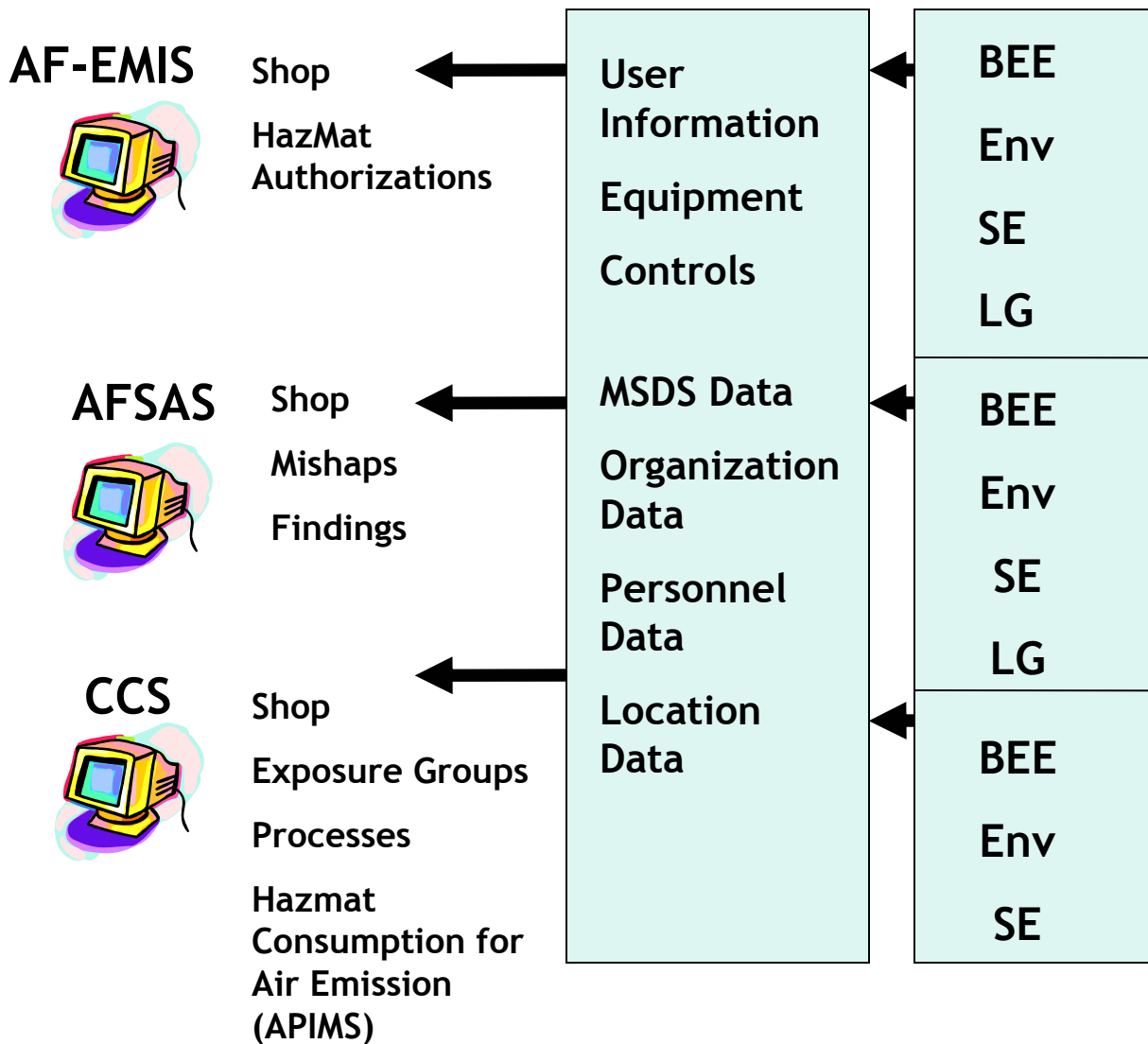



U.S. AIR FORCE

EESOH-MIS

AF-EMIS



Auto

AF/IEE



...and this scenario plays out 165 times across the AF...

AFSAS



Wing



CCS



Shop
Exposure Groups
Processes
Hazmat
Consumption for
Air Emission
(APIMS)

G

EE

Env

SE

Shop Floor





U.S. AIR FORCE

EESOH-MIS

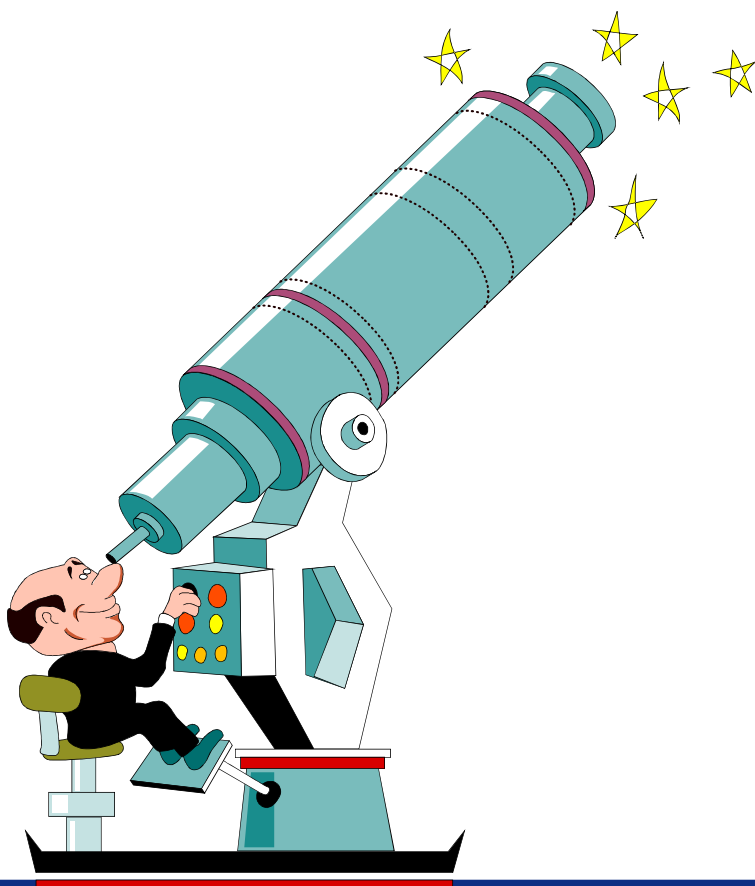

The Vision

Integrity - Service - Excellence



U.S. AIR FORCE

EESOH-MIS

STEWARDED DATA

Material & MSDS Data

Organization Data

Personnel Data

Location Data

BEE

Env

SE

LG

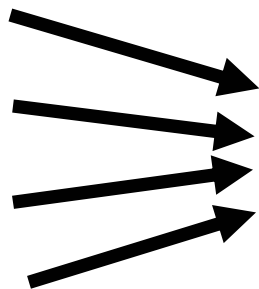

SHARED DATA

Shop

Process

Materials

Equipment

Controls



U.S. AIR FORCE

EESOH-MIS

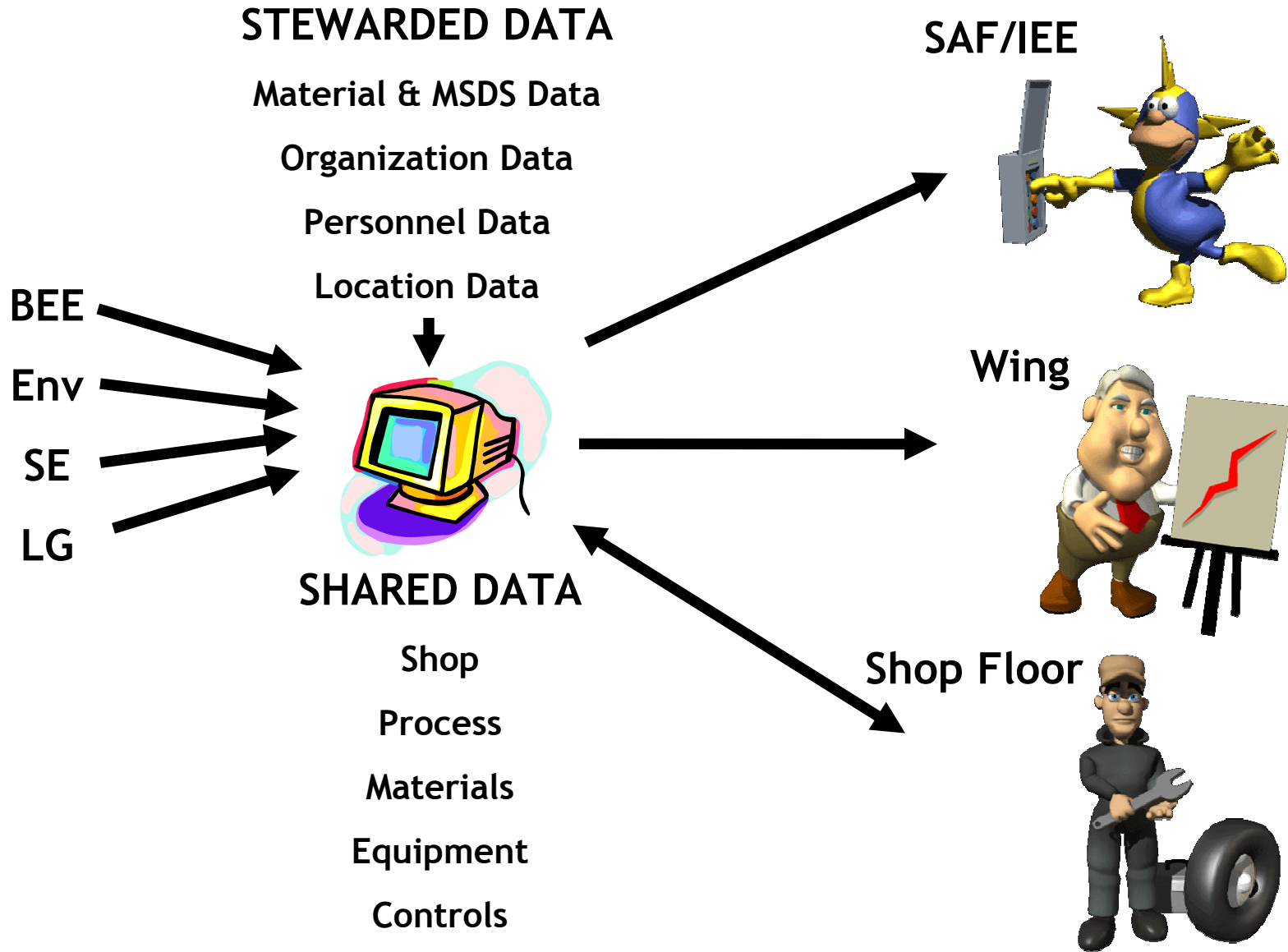



Understanding a Process

U.S. AIR FORCE

Core Processes Drive the Key Business Measurement Criteria

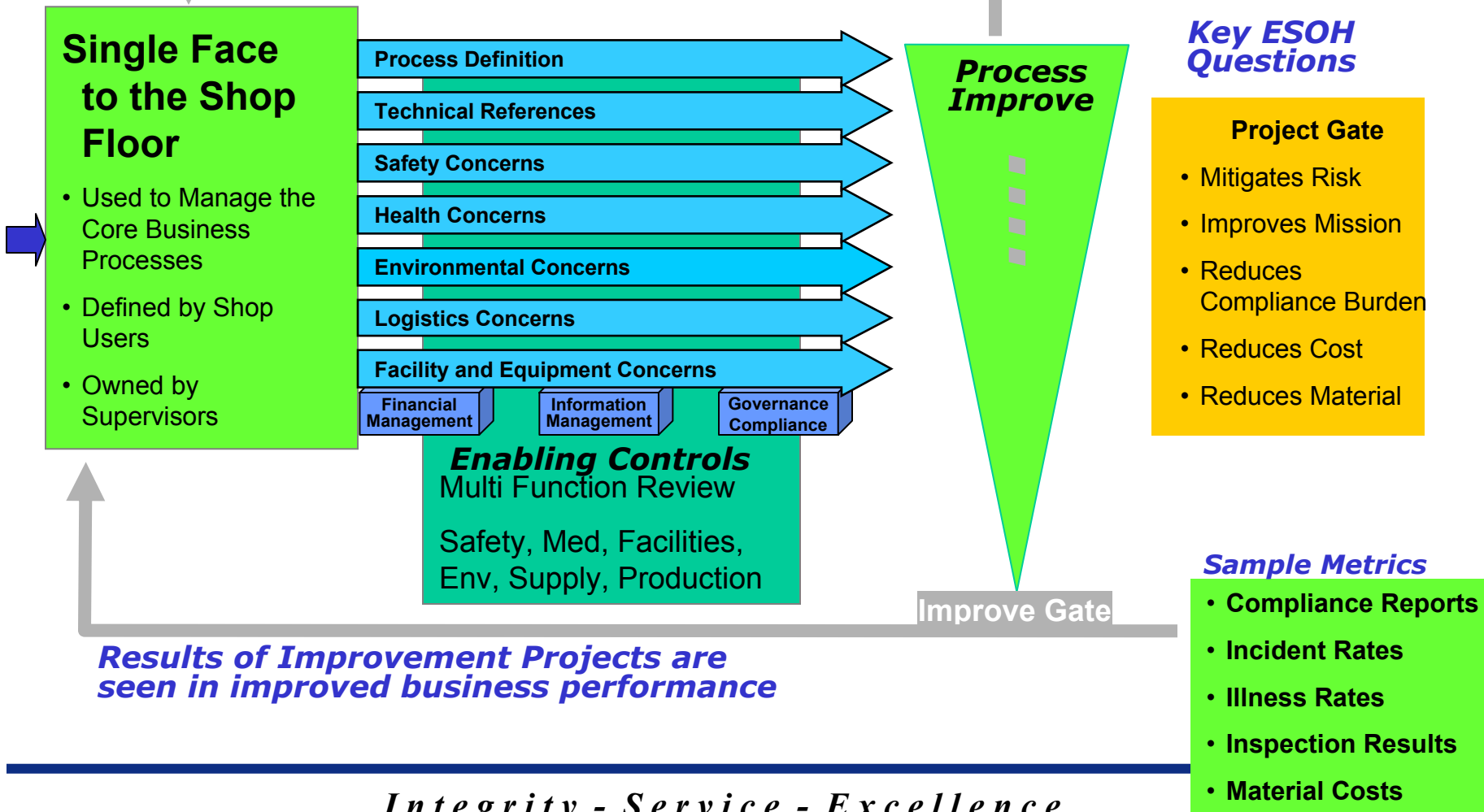



U.S. AIR FORCE

Authorizations Material to Process Centric

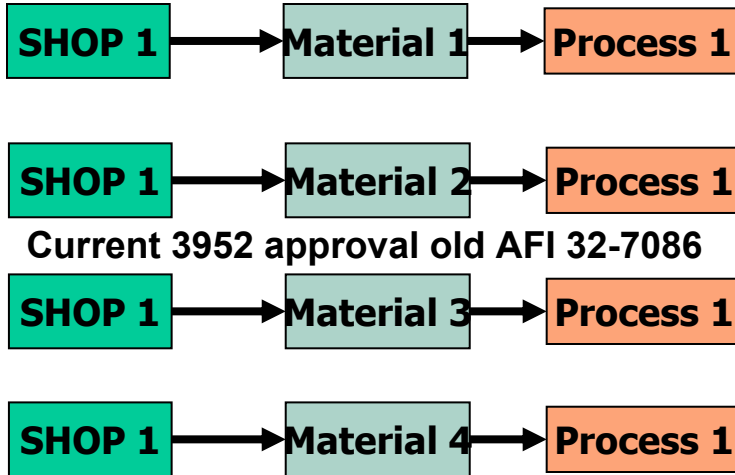

- Mostly Paper and Form Based procedure
- Manpower intensive
- Data collection intensive
- Communication intensive
- Time consuming
- Assessment of combined hazards difficult

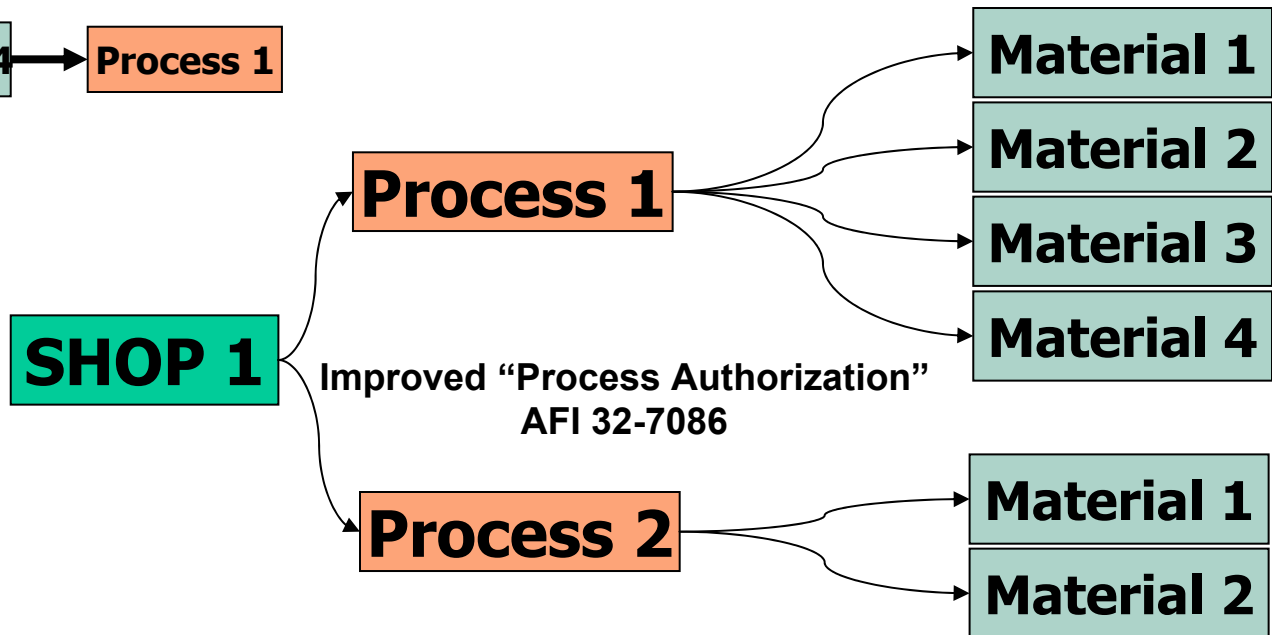

- AF Portal Authorization:
- All Materials
- Equipment
- Instructions
- Location specifics
- Concerns



U.S. AIR FORCE

Authorizations – To Be Process Centric

- Submit Authorization:
 - All Materials
 - Equipment
 - Location
 - Concerns

Process 1

- Monitor Authorization:
 - Aspects/Impact
 - Hazards
 - Controls
 - Exposure
 - PPE
 - Waste Characterization
 - Permit Requirements

Materials

Hazards

Controls

Exposure

PPE

Equipment

Waste Streams

Air Algorithms

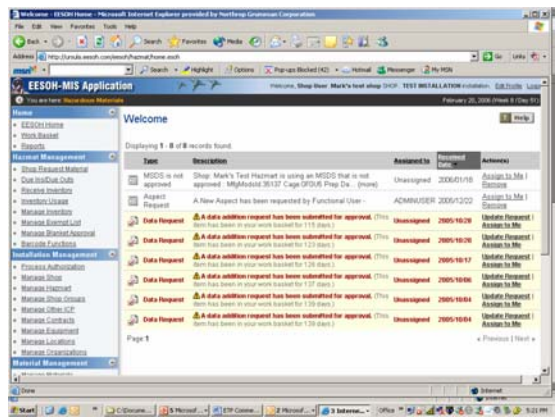
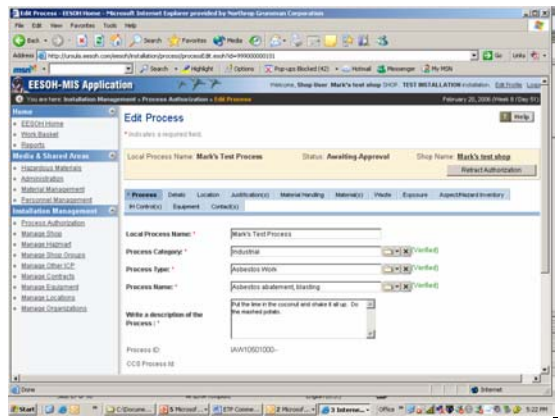



The Way Ahead

- **Process Remains the Key for Everything**
 - **Process Based MS**
 - **Process Based MIS**
 - **Process Based Activity Cost**
 - **Process Based Link to GeoBase**
 - **Process Based Issue and kits**
 - **Process Based**
- **Implementation of MS and MIS Must:**
 - **Be at the Installation Level**
 - **Incorporate Key Mission Areas**
 - **Show Commander a Benefit**



U.S. AIR FORCE

Single Face to the Shop Floor

One Stop Shopping for all E, S, OH constraints and requirements on the defined "Work Unit"

The screenshot displays the EESOH-MIS Application web interface. On the left, a navigation menu lists various management areas: Home, Media (Hazardous Materials, Hazardous Waste, Low-Level Radioactive Waste), Shared Applications (Administration, Installation Management), and Material Management. The main content area shows a 'Welcome' message and a table of records. A secondary window shows the 'Edit Process' form for 'Mark's Test Process', which is currently in an 'Awaiting-Approval' status. The form includes fields for Local Process Name, Process Category (Industrial), Process Type (Asbestos Work), and Process Name (Asbestos abatement, blasting). A description field contains the text: 'Put the lime in the coconut and shake it all up. Do the mashed potato.' The interface also shows a breadcrumb trail: Installation Management > Process Authorization > Edit Process.

Work defined once and used for All ESOH media and functions



Where You Fit

- **Air Staff**
 - Action on ODS and other AF controlled requests
 - Visibility into AF Best Practice
- **MajCom**
 - Action on ODS and other MajCom controlled requests
 - Visibility into AF Best Practice
- **Base Level HMMP**
 - Action to approve all HazMat requests
 - Insure Mission Requirements are met
- **Environmental**
 - Reviews and associates all Environmental Constraints
- **Safety**
 - Reviews and associates all Safety Constraints
- **BEE**
 - Reviews and associates all Health Constraints
- **UEC**
 - Approves Request for routing
- **Shop**
 - Submits Process Request

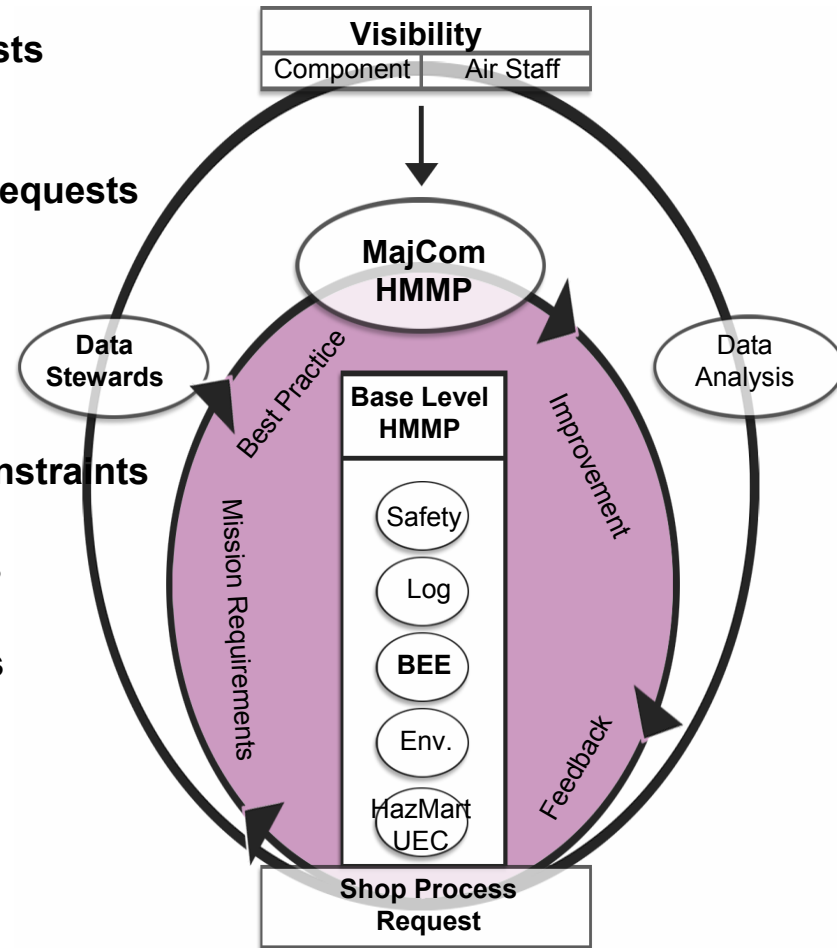



Reporting Improvements

U.S. AIR FORCE

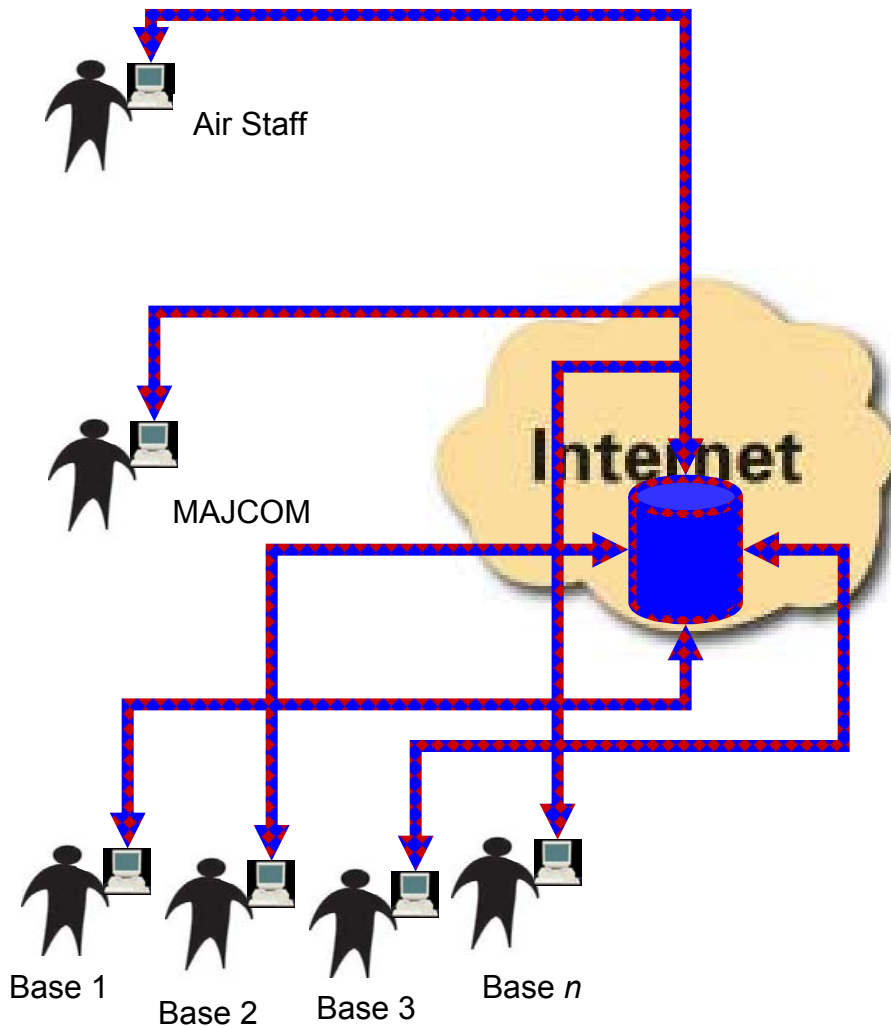

- **Single System Single Sign-on**
 - **No need for multiple servers and administrators**
- **Standard/stewarded data**
 - **Eliminate same entry by all bases (personnel, org, MSDS, trans,....)**
 - **Easier to consolidate info**
- **Easier data reporting**
 - **Upper management can perform what if scenarios without burdening bases**
 - **Shops don't have to compile data for different requests**
- **Users share information**
 - **Distributes data management burden**



U.S. AIR FORCE

The ESOH-MIS Vision agreed to by IE, IL, SG, SE, 2002

<i>Listed Integration Requirement</i>	<i>EESOH/DOEHRS</i>	<i>Score</i>
Fully Compliant with the AF GCSS IF	Yes	100%
Single Face To The Shop Floor	Yes	100%
No Redundant Data Entry	Yes	100%
Single Source Stewarded Data	Yes	100%
Common Data Structure	Yes	80%
Supports ABC Costing	In Work	
Integrates with GeoBase	In Work	
Common Look and Feel	Yes	80%
Data and Information Support to the ESOH MS	In Work	
Fully Supports Risk Based Management	E In Work, OH Yes	50%

Marching to the ESOH Transformation Vision

Integrity - Service - Excellence



U.S. AIR FORCE

EESOH Vision

One View to a World of Information

Civil Engineering



Logistics

Safety

Medical

Enterprise ESOH-MIS

Environment

Shop Floor

Working Together for Global Warfighter Support

Integrity - Service - Excellence



EESOH-MIS Booth 1219

U.S. AIR FORCE

EESOH-MIS
Booth 1219
across from
Cyber Cafe

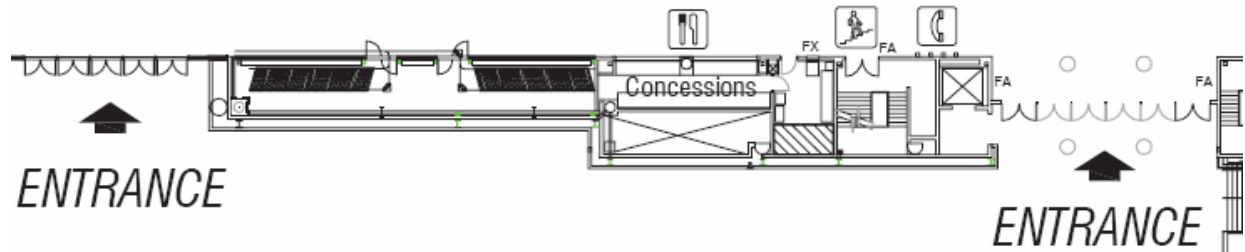
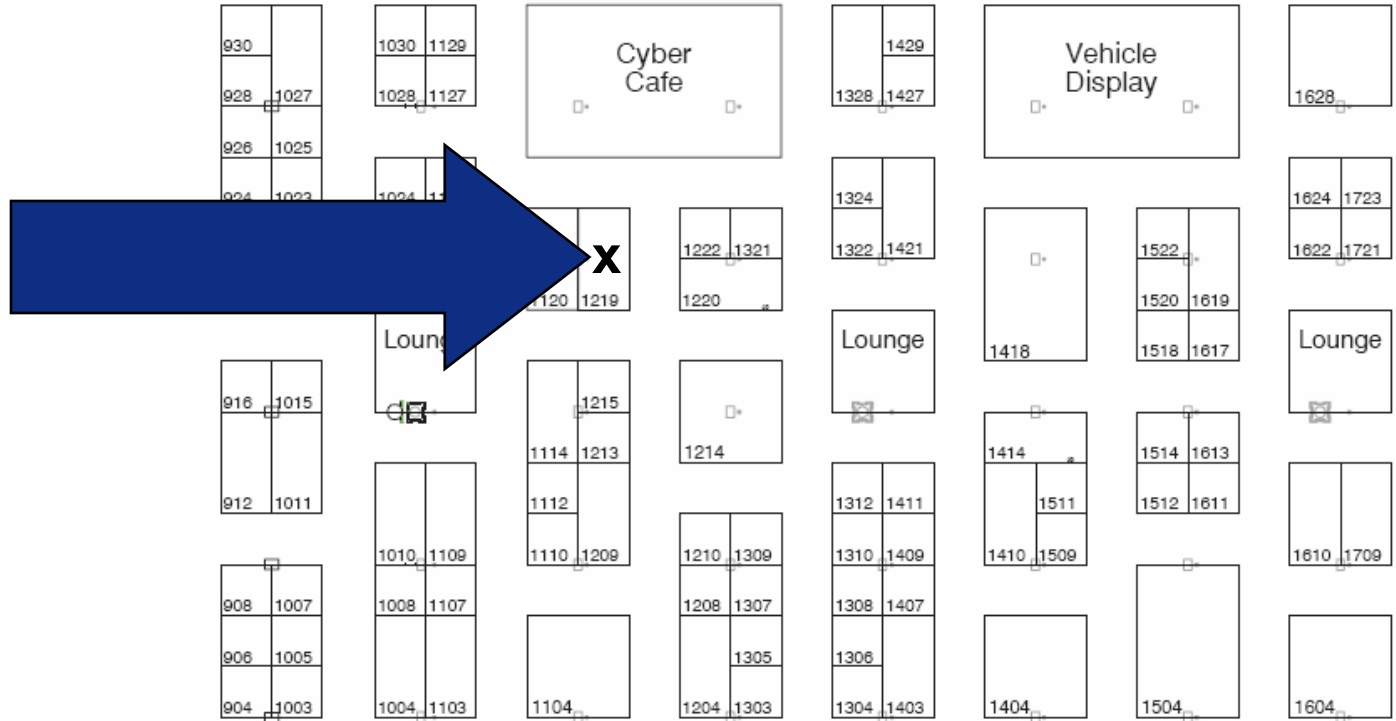

Questions?



U.S. AIR FORCE



U.S. AIR FORCE

Backup Slides



U.S. AIR FORCE

Technical Overview EESOH on the AF GCSS IF

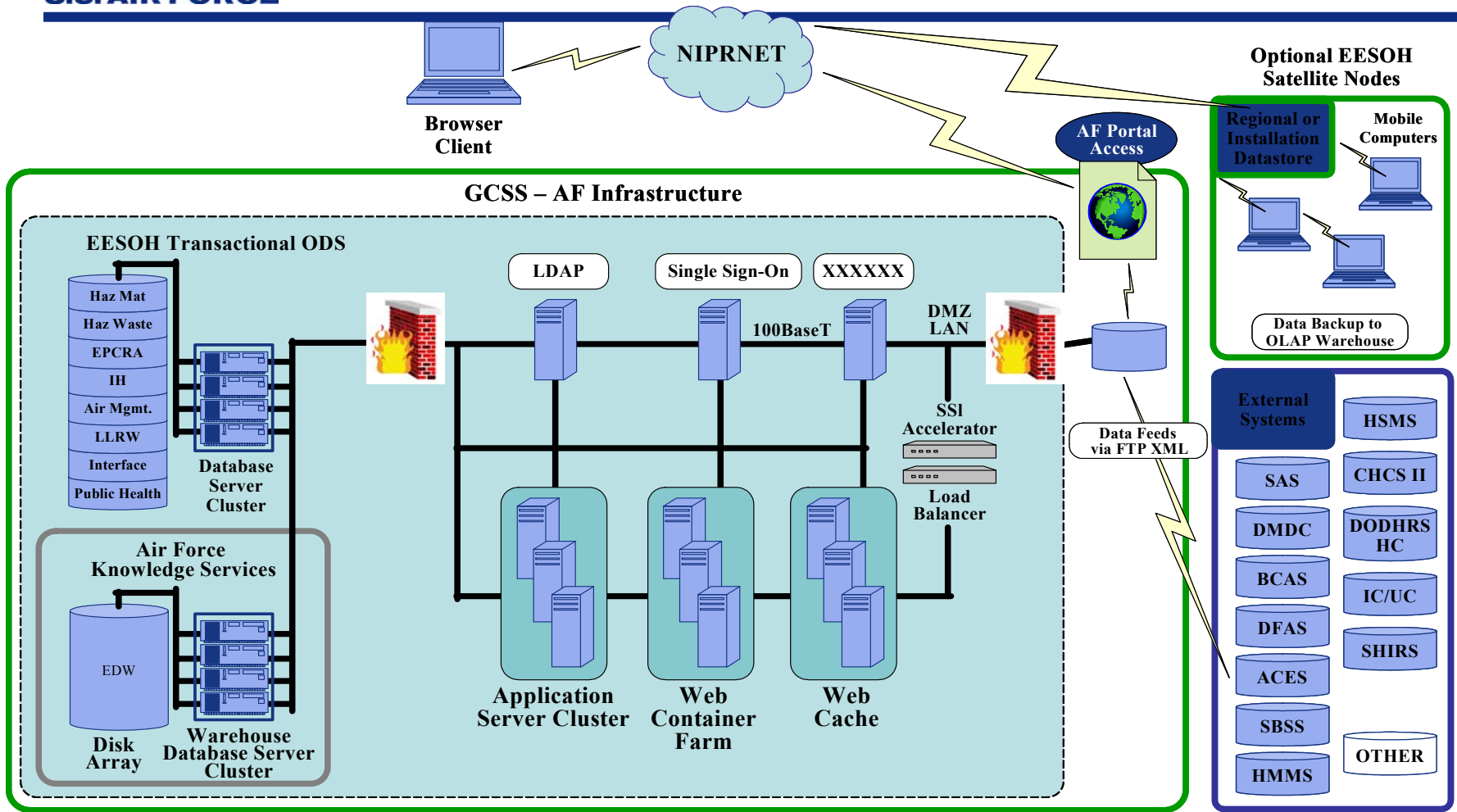

Reliance on GCSS Program Strength

Integrity - Service - Excellence



System Integration AF-wide

U.S. AIR FORCE

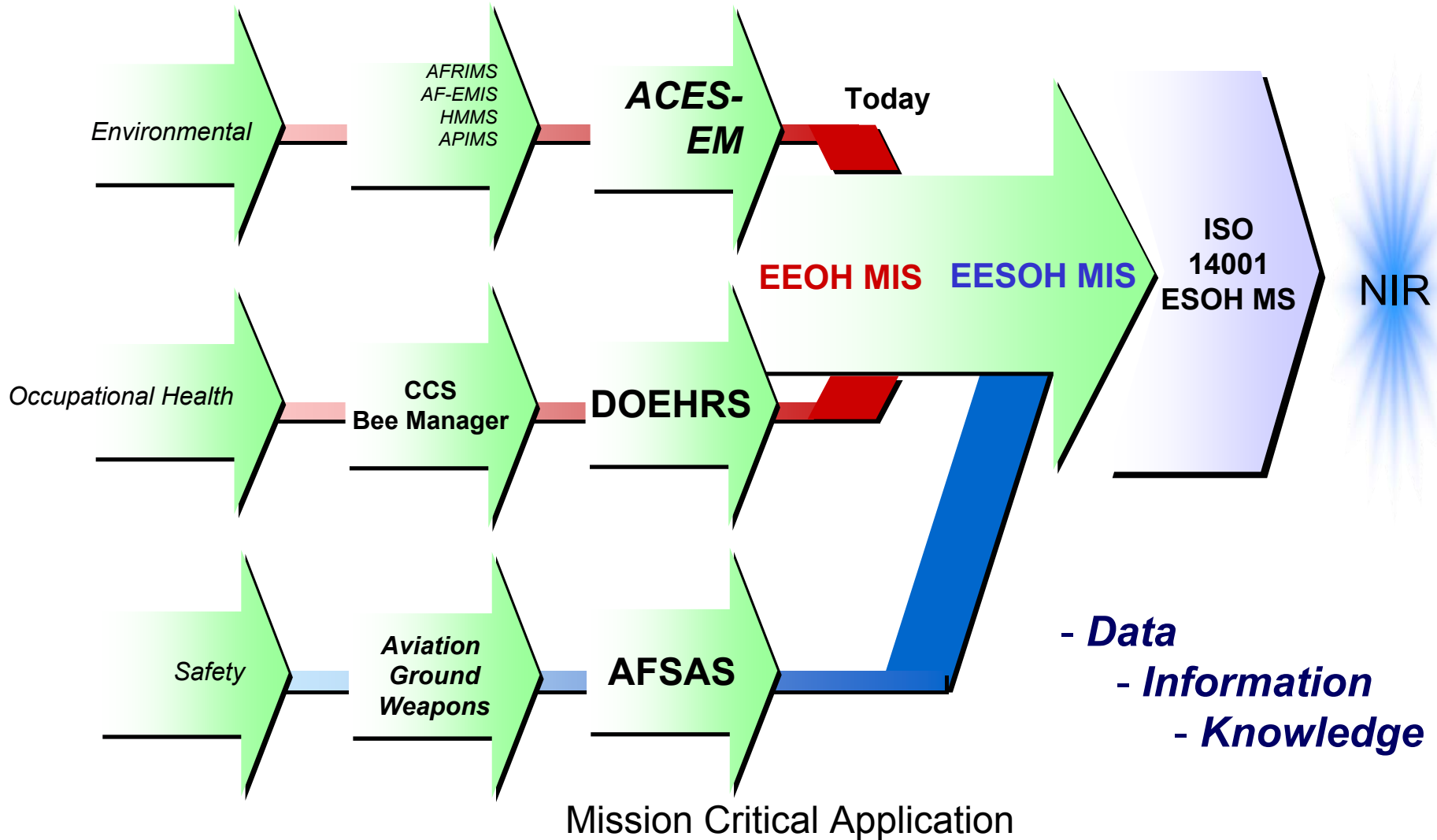

- Data
- Information
- Knowledge

Mission Critical Application



Base Level Compliance Reporting

U.S. AIR FORCE

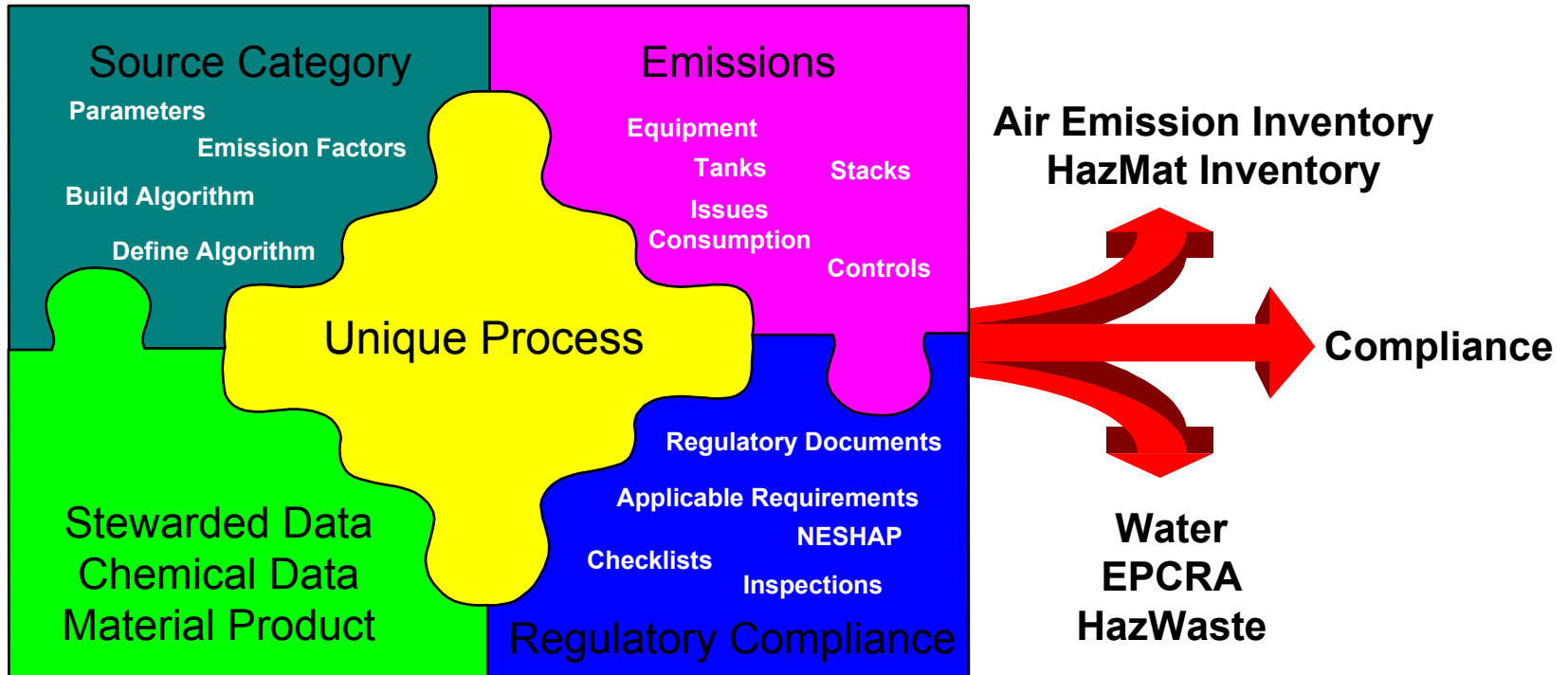

One Source of Data to Multiple Compliance Reports