



DOING BUSINESS WITH DEFENSE SUPPLY CENTER COLUMBUS

Eleanor Holland
Director, Small Business Office
(800) 262-3272 or (614) 692-3541



TOPICS



- **Brief DLA Overview**
- **Small Business Programs & Opportunities**
- **DSCC Small Business Goals**
- **Business Systems Modernization (BSM)**
- **DLA BSM Internet Bid Board System (DIBBS) Overview**
- **Where to Find More Information & Help**
- **Conclusion**



Defense Logistics Agency (DLA)



CORPORATE STAFF

DIRECTOR



DLA Director
Vice Admiral
Keith W. Lippert
Supply Corps,
United States Navy



Vice Director
Major General
Loren M. Reno
United States
Air Force

Coming Summer 05

SPECIAL
STAFF

VICE DIRECTOR



DLA
ENTERPRISE
SUPPORT



J-1
HUMAN
RESOURCES



J-3
LOGISTICS
OPERATIONS



J-4
CUSTOMER
OPERATIONS
& READINESS



J-6
INFORMATION
OPERATIONS



J-8
FINANCIAL
OPERATIONS



J-9
JOINT
RESERVE
FORCES



BUSINESS UNITS

DSCC



DSCR



DSCP



DESC



DDC



DRMS



SERVICE ACTIVITIES

DNSC

DLA-P



DLA-E



DLA-C



DLIS



DAPS



DLA SUPPLY CENTERS



DSCC - COLUMBUS
3990 EAST BROAD STREET
COLUMBUS, OH 43213-1152
TEL: (614) 692-3541 or
(800) 262-3272
Web Site: www.dsccl.dla.mil

DSCR - RICHMOND
8000 JEFFERSON DAVIS HWY
RICHMOND, VA 23297-5124
TEL: (804) 279-3287 or
1-800-227-3603
Web Site: www.dscr.dla.mil

DSCP - PHILADELPHIA
700 ROBBINS AVENUE
PHILADELPHIA, PA 19111-5092
TEL: (215) 737-2321 or
(800) 831-1110
Web Site: www.dscpl.dla.mil

DESC - DEFENSE ENERGY
SUPPORT CENTER
8725 JOHN KINGMAN DRIVE
FT. BELVOIR, VA 22060-6222
TEL: (703) 767-9400 or (800) 523-2601
Web Site: www.desc.dla.mil



Defense Supply Center Columbus

Maritime & Land Supply Chains



LAND SUPPLY CHAIN

- Gun Parts & Launchers
- Diesel Engines & Components
- Night Vision Equipment
- Power Transmissions Components
- Vehicle Cab, Body & Frame Components
- Water Purification Equipment
- Camouflage & Deception Equipment
- Brake, Axle, Wheel & Track Components

MARITIME SUPPLY CHAIN

- Steam Engines, Turbines & Components
- Valves and Pumps
- Pipe, Tubing, Hose & Fittings
- Separators & Filters
- Engine Fuel Systems
- Compressors
- Propulsion Components
- Marine hardware & Hull Items
- Electronic Components & Fiber Optics

AEROSPACE DETACHMENT of DSCR

DLA COMMODITIES: http://www.supply.dla.mil/build_fsc.asp



Defense Supply Center Richmond

Aerospace Supply Chain



AEROSPACE SUPPLY CHAIN

- Aircraft Wheel & Brake Systems
- Propellers
- Landing Gear Components
- Flight Instruments
- Motors, Electrical
- Batteries
- Wire and Cable
- Chemicals

LAND DETACHMENT of DSCC

MARITIME DETACHMENT of DSCC

DLA COMMODITIES: http://www.supply.dla.mil/build_fsc.asp



Defense Supply Center Philly

Troop Support



CLOTHING & TEXTILES

- Outerwear
- Hats, Accessories
- Individual Equipment
- Sleeping Bags
- Body Armor

SUBSISTENCE

- Meals Ready to Eat
- Field Mess Equip
- Dining Hall Items
- Fruits & Vegetables

MEDICAL

- X-Ray Machines
- MRI Equipment
- Surgical Supplies
- Dental Supplies
- Optical Products

LAND
DETACHMENT of DSCC

MARITIME
DETACHMENT of DSCC

AEROSPACE
DETACHMENT of DSCR

DLA COMMODITIES: http://www.supply.dla.mil/build_fsc.asp



Small Business Programs



Programs with Set Aside Authorization



YES

Small Business Program

YES

Section 8(a) Business Development

YES

HUBZone Program

YES

Service Disabled Veteran Owned
Small Business (SDVOSB) Program

NOTE: No solicitation estimated under \$2,500
can be set-aside under any program



Programs Without Set Aside Authorization



NO

Small Disadvantaged Business

NO

Veteran Owned Business

NO

Women Owned Business



Small Business Set Aside Program



SB Set-aside Participation Requirements



- Must be a small business concern:
 - organized for profit
 - Located in the United States
 - Makes significant contribution to the economy through payment of taxes and/or use of American products, materials, and/or labor
 - qualifies as small under the size standard for the North American Industry Classification System (NAICS) code specified in the solicitation



SB Set-aside Program Performance Requirements



- Contract for Supplies or Products (may be a manufacturer or non-manufacturer)
 - manufacturer
 - perform at least 50 percent of the cost of manufacturing the products (not including the costs of materials)
 - non-manufacturer (non-manufacturers rule)
 - must supply the product of a domestic small business manufacturer



8(a) Business Development Set Asides



8(a) Requirements



To be Certified by the SBA as an 8(a) firm:

- Must be a small business
- Owned and controlled by socially and economically disadvantaged individual(s)
- Individual(s) must be of good character and a U.S. citizen(s)
- Must demonstrate potential for success



8(a) Set Aside Requirements



For an 8(a) set-aside:

- Company must be a current 8(a) program participant (only one 9 year term)
- Capabilities must match the requirement
- Award price cannot exceed the Government's established "fair market price"
- SBA must accept the requirement for the 8(a) program



HUBZone Set Aside Program



HUBZone Program Requirements



- Must be a small business concern
- Must be a certified HUBZone Small Business Concern (SBC)
 - Small Business Administration certifies the HUBZone SBC as qualified for federal contracting assistance under the HUBZone program



HUBZone Set-aside Performance Requirements



- Same for small business set asides except:
 - HUBZone company must spend at least 50% of the manufacturing cost (excluding materials) on performing the contract in a HUBZone
 - There is no provision for a waiver to the non-manufacturers rule for HUBZone Set Asides
 - Qualified HUBZone non-manufacturer must furnish only end items produced by HUBZone manufacturers - except:
 - Awards between \$2,500 & \$25,000 - a qualified HUBZone company may supply the end item of any manufacturer, including a large business



Service Disabled Veteran Owned SB Program Requirements



- Must be a small business concern
- Not less than 51% owned by a service-disabled veteran(s) or, if publicly owned, not less than 51% of the stock is owned by a service-disabled veteran(s)
- Management & daily business operations are controlled by a service-disabled veteran(s)



Service Disabled Veteran Owned Program Performance Requirements



- SDVOSB supplier may produce the item or provide the item manufactured by a domestic small business concern
- Award can be made at a “fair market price”

NOTE: SDVOSB set-asides may be sole source or competitive based on the contracting officer’s decision as to whether there are 2 or more SDVOSB able to perform



SBA's Key Internet Addresses

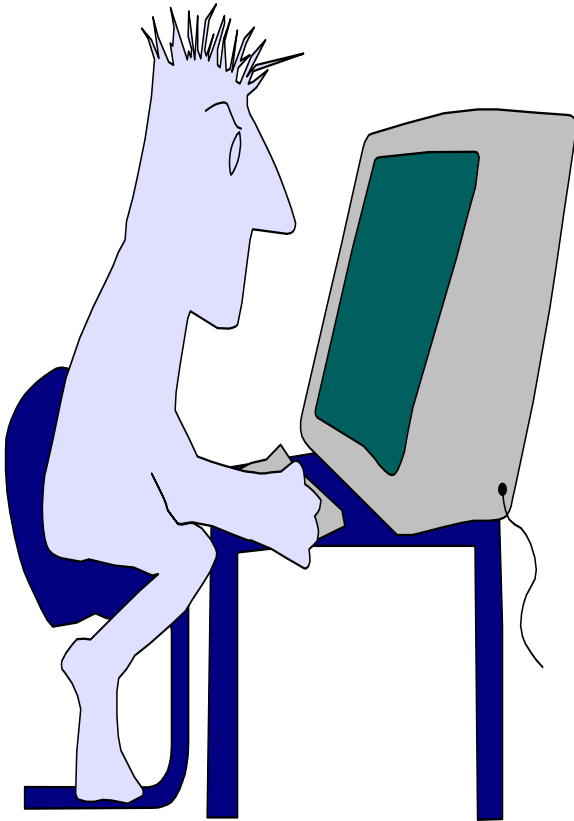

- SBA's Home Page:
www.sba.gov
- Government Contracting:
www.sba.gov/GC
- 8(a) Business Development:
www.sba.gov/8abd
- HUBZone:
www.sba.gov/hubzone



DSCC SMALL BUSINESS GOALS



	FY04 GOALS	FY04 ACTUALS	FY05 GOALS
SMALL BUSINESS	56.8%	66.5%	58.2%
HUBZone	2.5%	3.9%	3.0%
SDB	4.7%	3.9%	3.7%
WOMAN OWNED	5.0%	10.1%	5.9%
SERVICE DISABLED	3.0%	0.33%	3.0%
8(a) (SDB Subset)	0.50%	0.69%	.50%



DLA TRANSFORMATION



Over the past five years DLA has crafted a robust transformation strategy that is now being deployed through a comprehensive portfolio of programs and initiatives

BSM is one of the main initiatives



BSM



Business Systems Modernization:

- DLA's Commercial-Off-The-Shelf-based Enterprise Resource Planning (ERP) system
- Designed to deliver re-engineered materiel planning, order fulfillment, procurement and financial management processes
- BSM Release 1 “went live” 7/02 with 170,000 items
- Full scale deployment began 11/03
- All of DLA's 4.6 million items and the personnel who manage them are on track to be operating exclusively in the BSM environment in 2006



Selling to DLA under BSM



All DLA Solicitations will be available
on one web site in '06: **DLA BSM DIBBS**

- **DLA BSM DIBBS:**

<https://www.dibbs.bsm.dla.mil/>

- **Until all items migrate, non-BSM opportunities are at:**

- **DSCP and DSCR: PROCUREMENT GATEWAY**
<http://progate.daps.dla.mil/home/>
- **DSCC: ORIGINAL VERSION OF DIBBS**
<http://dibbs.dsccl.dla.mil/>



DLA BSM DIBBS



- **View and submit quotes**
- **View RFPs – Includes Long Term Contracts & EMail Opportunities**
- **Access award information**
- **View provisions, clauses & packaging specs**
- **View price history**
- **View Technical Data**
- **Access the Automated Best Value System (ABVS) (Scores used in award decision process)**

Note: Forecasts will not be initially available in BSM DIBBS



DSCC DIBBS **vs.** DLA BSM DIBBS



FUNCTIONALITY: VIRTUALLY THE SAME

THE LOOK: SLIGHTLY DIFFERENT

Let's go to DSCC's Home Page

www.dsccl.dla.mil



Defense Supply Center Columbus

Taking the Lead in Land, Maritime, and Missile Support

**Opening
DLA BSM DIBBS**

- Customer Contact Center (24 hr/7day)**
- [Business Systems Modernization \(BSM\)](#)
- [DLA-BSM Internet Bid Board System \(DIBBS\)](#)
- [DSCC Internet Bid Board System \(DIBBS\)](#)
- [Points of Contact](#)
- [Administrative Services](#)
- [DoD Electronic Mail \(EMALL\) Information](#)
- [DLA Small Business Program](#)



Buying from

Selling to

- Doing Business with DSCC
- Vendor Assistance
- DLA-BSM Internet Bid Board System (DIBBS)**
- DSCC Internet Bid Board System (DIBBS)
- Business Opportunities
- Global War on Terrorism (GWOT) Initiative
- Corporate Contract/Tailored Support Solicitations
- DLA Packaging Web Site
- Value Engineering Change Proposal (VECP)
- Automated Best Value System (ABVS) Program

Selling to DSCC



News and Events

Links

DLA BSM DIBBS

www.dibbs.dla.mil

number (NSN) or Federal
items and users into
table. Additional

Help

- Help
 - [Frequently Asked Questions ~ FAQ](#)
 - [DIBBS On-Line Quoting Help](#)
 - [Batch Quoting Help](#)
- Contact Us

Solicitations

- Requests for Quotation (RFQ)
 - [RFQ Auctions](#)
 - [Batch Quoting](#)
 - [Submitted Quote Searching](#)
- Requests for Proposal (RFP) / Invitation For Bid (IFB)
- Other DLA Opportunities

References

- [BSM Program NSN/FSC Query Database](#)
- [All FSCs managed by DLA](#)
- [Master Solicitation Documents](#)
- [Regulation Extracts used for DIBBS quoting](#)
- [Virtual Library](#)
- [Automated Best Value System \(ABVS\)](#)

Notices

- | | |
|---|------------------------|
| New NSNs Being Migrated to BSM on September 1, 2004 | 09/01/2004 06:59:36 PM |
| Subsistence Vendors | 08/20/2004 07:41:02 AM |
| Vendor Remittance Information | 08/20/2004 07:35:46 AM |
| Subsistence BPAs for Fresh Fruits and Vegetables (Instructions for Electronic Distribution, Review, and Acceptance) | 08/12/2004 03:57:54 PM |
| Proper Invoicing | 07/20/2004 12:00:00 AM |

Vendor Registration

FAQs

Awards

- [Awards](#)
- [Other DLA Awards](#)
- [Subsistence Blanket Purchase Agreements \(BPAs\)](#)

Technical Data

- [DLA-BSM Bidset Interface](#)
- [DoD Specifications and Standards](#)

SOLICITATIONS/SEARCHING

- Welcome
- User Guide
- Registration
- Solicitations
- Quoting
- Frequently Asked Questions
 - Alternate Offers
 - Awards
 - Bid Type
 - DIBBS Sessions
 - DIBBS Training
 - Drawings and Bidsets
 - Error Messages
 - Getting Started and Registration
 - Miscellaneous
 - Problems
 - Quoting
 - Solicitations and Searching
 - Super User and My Account
 - Surplus
 - User IDs and Passwords

11. [On the RFQ Search Results Page, there are various icons such as a capital red F and a capital SB as well as others. What do these icons mean?](#)
12. [Can I fax my quote?](#)
13. [I can't find a particular solicitation. What am I doing wrong?](#)
14. [When searching for a solicitation, I get a message that the requirement is no longer available on DIBBS. Will I be able to quote this?](#)
15. [The solicitation requires origin inspection and the quote form is asking me for a Place of Inspection, Supplies CAGE Code and Place of Inspection Packaging CAGE code. Where do I get this information?](#)
16. [I noticed that your solicitations have different numbers in the 4th position of the solicitation number. Why?](#)

BID TYPE

17. [What is the difference between "Bid Without Exception" and "Bid With Exception"?](#)
18. [I have supplied the item in the past to the Government and I have been approved, but I am not listed as a source on the solicitation?](#)
19. [The cage code of the approved source and/or part number has been changed or is incorrect on the solicitation. How do I quote this?](#)

QUOTING

20. [How do I submit a quote on DIBBS?](#)
21. [Can I submit my quote after the closing date?](#)
22. [Can I change my quote once it has been submitted?](#)
23. [How do I know if I submitted my quote successfully?](#)

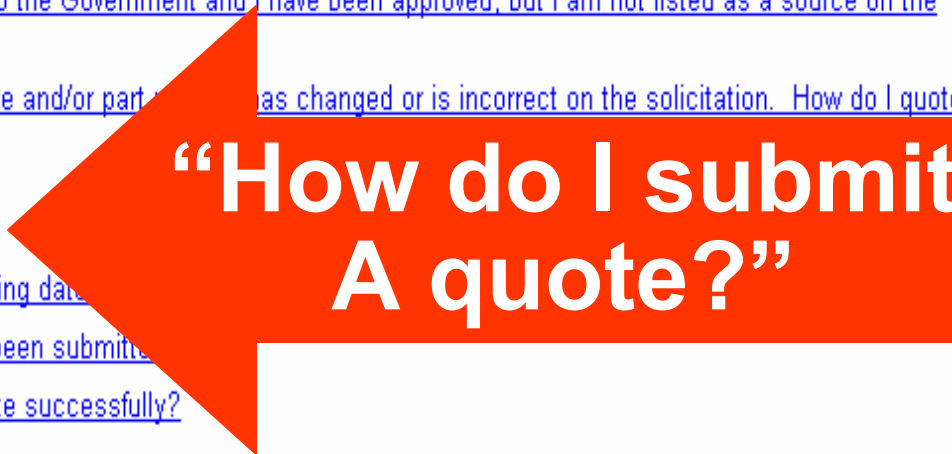

AWARDS

24. [I need to find an award. How do I do this?](#)
25. [A vendor, other than the lowest bidder, was awarded the contract. Why did they get the award?](#)

How do I submit a quote?

[Print Topic](#)

20. How do I submit a quote on DIBBS?

A user must be registered and logged into DIBBS in order to submit quotes.

Through Web Form Quoting, find your Solicitation via the RFQ Search and then click on the  [quote](#) icon displayed next to the solicitation number on the search results.

- After finding a solicitation on which you would like to submit a quote click on the "Quote" button. If you are not already logged on, you will be prompted to do so.
- Business rules for submitting quotes are available via on-line help.
- Click on "Submit" after completing the quote form and reviewing the synopsis of your quote for accuracy.
- The system will provide a message that the quote submittal was "Successful" or "Unsuccessful."
- Submitted quotes may be viewed until such time that the requirement is awarded/cancelled. Revisions to quotes submitted on behalf of a CAGE will overlay any previously submitted quote for the same requirement.
- Users are reminded that representations and certifications incorporated in individual quotes are binding in their entirety. Any penalties for misrepresentation contained in the referenced provisions still apply (e.g. penalties for misrepresentation of business status under FAR 52.219-1, paragraph (d)(2)).

If you know the solicitation number which you would like to quote, you may use Fast Trak Quoting and go directly to step one of the quote form by-passing the RFQ search.

Fast Trak Quoting

Solicitation #:



(Enter without dashes or spaces)

You can also quote on multiple solicitations through Batch quoting. Batch Quoting allows quotes on DSCC Request for Quotations to be batch uploaded. Quotes are prepared offline in a prescribed comma delimited format then uploaded via the Internet. You can find batch download files from the Welcome page (when you first log-on to DIBBS) or under the "Solicitation" tab on the Home page.

- Quoting
- Frequently Asked Questions
 - Alternate Offers
 - Awards
 - Bid Type
 - DIBBS Sessions
 - DIBBS Training
 - Drawings and Bidsets
 - Error Messages
 - Getting Started and Registration
 - Miscellaneous
 - Problems
 - Quoting
 - Solicitations and Searching
 - Super User and My Account
 - Surplus
 - User IDs and Passwords

Requests For Quotation - RFQs

eral
into

**Start Search
Under \$100K**

Help	
<ul style="list-style-type: none"> Help <ul style="list-style-type: none"> Frequently Asked Questions ~ FA DIBBS On-Line Quoting Help Batch Quoting Help Contact Us 	
Solicitations	Awards
<ul style="list-style-type: none"> Requests for Quotation (RFQ) <ul style="list-style-type: none"> RFQ Auctions Batch Quoting Submitted Quote Searching Requests for Proposal (RFP) / Invitation For Bid (IFB) Other DLA Opportunities 	<ul style="list-style-type: none"> Awards Other DLA Awards Subsistence Blanket Purchase Agreements (BPAs)
References	Technical Data
<ul style="list-style-type: none"> BSM Program NSN/FSC Query Database All FSCs managed by DLA Master Solicitation Documents Regulation Extracts used for DIBBS quoting Virtual Library Automated Best Value System (ABVS) 	<ul style="list-style-type: none"> DLA-BSM Bidset Interface DoD Specifications and Standards
Notices	
<ul style="list-style-type: none"> New NSNs Being Migrated to BSM on September 1, 2004 Subsistence Vendors Vendor Remittance Information Subsistence BPAs for Fresh Fruits and Vegetables (Instructions for Electronic Distribution, Review, and Acceptance) Proper Invoicing 	<ul style="list-style-type: none"> 09/01/2004 06:59:36 PM 08/20/2004 07:41:02 AM 08/20/2004 07:35:46 AM 08/12/2004 03:57:54 PM 07/20/2004 12:00:00 AM

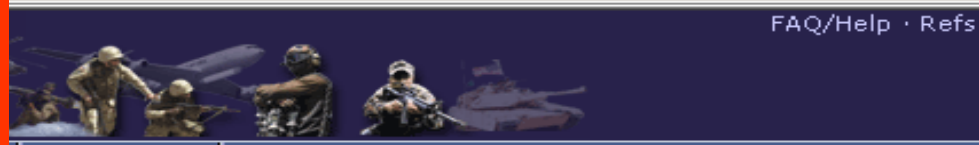

Awards

Search: Choose Search

Log

ations]

Text Search

Search RFQ text for any word(s) or phrase(s).

RFQ DATABASE SEARCH

RFQ Database Search

Search Categories:
 National Stock Number (4)
 National Stock Number (4)
 Federal Supply Class (4)
 Solicitation Number (6)
 Purchase Request Number (8)
 Nomenclature (4)
 Approved Part Number (4)
 Approved CAGE (5)

Reset Submit >>

Scope. Show RFQs only for:
 All

Sorted by:
 NSN

Then By Sorted by:

Show Only:

Items with Bid Sets **BWG**

Fast Award Candidates **F**

Small Business Set Asides **SB**

IDPO Solicitations **IDPO**

RFQ Text Search

Enter your query:

SEARCH CATEGORIES

- NATIONAL STOCK #
- FEDERAL SUPPLY CLASS
- SOLICITATION #
- PURCHASE REQUEST #
- NOMENCLATURE
- APPROVED PART #
- APPROVED CAGE CODE

■ **Custom Queries**
Search the RFQ Database.

■ **Text Search**
Search RFQ text for any word(s) or phrase(s).

RFQ Database Search

Search Categories:
National Stock Number (4)

Search Value(s): *

RFQ Text Search

Enter your query:

Scope. Show RFQs only for:

All

Today

Recent

Open

Closed (but not Awarded)

All

Show Only:

Items with Bid Sets **DWG**

Fast Award Candidates **F**

Small Business Set Asides **SB**

IDPO Solicitations **IDPO**

SCOPE:

- TODAY
- RECENT – PAST WEEK
- OPEN – PAST 2 WEEKS
- CLOSED – NOT AWARDED
- ALL



BUT NOT with the word VARIABLE

Solicitations

RFQs

RFP/IFPs

Tech Data

Downloads

Awards

Navigation:

Navigation/Documents

Search:

Choose Search

» Solicitations » **RFQs**

LOGGED OFF

h | [Recent RFQs](#) | [RFQs by Issue Dt](#) | [RFQs by Return By Dt](#) | [FSCs](#) | [RFQ Auctions](#)]

[37] 02/06/20

Custom Queries

Search the RFQ Database.

RFQ Database Search

Search Categories:
National Stock Number (4)

Search Value(s): *

Scope. Show RFQs only for:

All

Sorted by:

NSN

Then By Sorted by:

- NSN
- Nomenclature
- PR
- Solicitation
- Issue Date
- Return By Date

 Small Business Set Asides IDPO Solicitations**Text Search**

Search RFQ text for any word(s) or phrase(s).

RFQ Text Search

Enter your query:

SORTING OPTIONS:

- NSN
- NOMENCLATURE
- PR
- SOLICITATION
- ISSUE DATE
- RETURN BY DATE



Custom Queries
 Search the RFQ Database.

RFQ Database Search

Search Categories:
 National Stock Number (4)

Search Value(s): *

Reset Submit >>

Scope. Show RFQs only for:
 All

Sorted by:
 NSN

Then By Sorted by:

Show Only:

Items with Bid Sets **DWG**

Fast Award Candidates **F**

Small Business Set Asides **SB**

IDPO Solicitations **IDPO**

Text Search
 Search RFQ text for any word(s) or phrase(s).

RFQ Text Search

Enter your query:

Modified: at any time.

Clear Execute

SHOW ONLY SOLICITATIONS MEETING THE SELECTED CRITERIA

TEXT SEARCH "HOSE"

Custom Queries

Search the RFQ Database.

RFQ Database Search

Search Categories:
National Stock Number (4)

Search Value(s): *

Scope. Show RFQs only for:
All

Sorted by:
NSN

Then By Sorted by:

Show Only:

Items with Bid Sets

Text Search

Search RFQ text for any word(s) or phrase(s).

RFQ Text Search

Enter your query:

HOSE

Modified: at any time.

Additional Text Search Help

Search Examples:
Combination Text, Phrase:

Enter: RESISTOR* AND "WIRE WOUND"
Results yield documents containing
the word RESISTOR, phrase "WIRE WOUND"

Enter: RESISTOR* AND "WIRE WOUND" AND
NOT "VARIABLE"
Results yield documents containing
the word RESISTOR, phrase "WIRE WOUND"
BUT NOT with the word VARIABLE

TEXT SEARCH RESULTS

Documents 1 to 50 of 465 matching the query "HOSE" sorted by latest *Creation Date Time* posting.

#	Solicitation Number	RFQ/Quote Status	Auction Status	Bidset/ Drawings	Spec/ Std	Issued	Return B		
1.	SPM70005T4335.HTML	Quote		Avail	Avail	2/6/2005	2/20/2005		
2.	SPM70005T4285.HTML	Quote			None	2/6/2005	2/20/2005		
3.	SPM70005T4272.HTML	Quote		Avail	None	2/6/2005	2/20/2005		
4.	SPM70005T4234.HTML	Quote			None	2/6/2005	2/20/2005		
5.	SPM70005T4226.HTML	Quote			None	2/6/2005	2/20/2005		
6.	SPM70005T4209.HTML	Quote			None	2/6/2005	2/20/2005		
7.	SPM70005T4186.HTML	Quote			Avail	2/6/2005	2/20/2005	12119	2/6/2005 5:15:54 AM GMT
8.	SPM70005T4184.HTML	Quote			Avail	2/6/2005	2/20/2005	11156	2/6/2005 5:15:53 AM GMT
9.	SPM76005Q0390.PDF	Quote			Avail	2/1/2005	2/15/2005	27869	2/2/2005 5:15:29 AM GMT
10.	SPM70005T3997.HTML	Quote			None	2/1/2005	2/15/2005	10832	2/1/2005 5:15:29 AM GMT
11.	SPM70005T3922.HTML	Quote			None	1/28/2005	2/11/2005	10977	1/28/2005 5:15:22 AM GMT

NOT SHOWN WITH TEXT SEARCH:

- NOMENCLATURE
- QUANTITY
- BUYER CODE w/ LINK
- PURCHASE REQUEST #

SEARCH FSC 4720 HOSE & TUBING, FLEXIBLE

Custom Queries

Search the RFQ Database.

RFQ Database Search

Search Categories:
Federal Supply Class (4) ▼

Search Value(s): *
4720

Scope. Show RFQs only for:
All ▼

Sorted by:
NSN ▼

Then By Sorted by:
▼

Show Only:

Items with Bid Sets DWG

Fast Award Candidates F

Small Business Set Asides SB

IDPO Solicitations IDPO

Text Search

Search RFQ text for any word(s) or phrase(s).

RFQ Text Search

Enter your query:

Modified: at any time. ▼

Additional Text Search Help ?

Search Examples:

Combination Text, Phrase:

Enter: RESISTOR* AND "WIRE WOUND"
Results yield documents containing
the word RESISTOR, phrase "WIRE WOUND"

Enter: RESISTOR* AND "WIRE WOUND" AND
NOT "VARIABLE"
Results yield documents containing
the word RESISTOR, phrase "WIRE WOUND"
BUT NOT with the word VARIABLE

LET'S REVIEW OUR SEARCH RESULTS

Records 1 thru 48 of 48 Records.
Page: 1

Click on the Solicitation # to view the RFQ & NSN/Part No. to view additional info.

#	NSN/Part No. Nomenclature	Bidset/ Drawings	Spec/ Std	Solicitation #	Auction Status	PR # PR QTY	Issue	Return By
1	4720-00-061-2080 HOSE, AIRDUCT		None	SPM700-04-T-0838	Quote	0010531227 QTY: 2	6/11/2004	06/21/2004
2	4720-00-061-2080 HOSE, AIRDUCT		None	SPM700-04-T-2320	Quote	001066 QTY: 1		
3	4720-00-134-4283 HOSE, AIRDUCT		None	SPM700-05-T-2112	Quote	001095 QTY: 3		
4	4720-00-143-3830 HOSEASSEMBLY, NONMETAL		None	SPM700-05-T-2390	Quote	001097 QTY: 16		
5	4720-00-278-1109 HOSE, NONMETALLIC Mil-Spec			-2237	Quote	001096 QTY: 76		
6	4720-00-278-4890 HOSE, NONMETALLIC, 5/ Mil-Spec			-0261	Quote	001089 QTY: 5423	12/27/2004	01/06/2005
7	4720-00-613-7268 HOSEASSEMBLY, NONME Mil-Spec QPL			-2158	Quote	0010956733 QTY: 3	12/27/2004	01/10/2005
8	4720-00-891-0494 HOSEASSEMBLY, NONMETAL			SPM700-05-T-2394	Quote	0010979257 QTY: 4	1/7/2005	01/21/2005
9	4720-00-903-0462 HOSEASSEMBLY, NONMETAL	Avail	None	SPM700-05-T-1883 SB	Quote	0010926782 QTY: 53	12/10/2004	12/29/2004
10	4720-00-918-0714		None	SPM700-05-T-2316	Quote	0010850505 QTY: 1	12/1/2004	12/15/2004

**NOT SHOWN
IN THIS
SEARCH:**

- BUYER CODE
w/ LINK







**NEW IN THIS
SEARCH:**

- Mil-Spec
- QPL

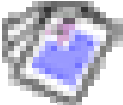

SOLICITATION ICONS



	<p>By clicking, you can quote on a solicitation (if logged in)</p>
	<p>There is a drawing available for the NSN (click to access the drawing)</p>
	<p>There is a specification or standard available for download (click to access)</p>
	<p>This solicitation is set-aside for small business participation <u>only</u></p>
	<p>The NSN is a Military Specification / Quality Products List item</p>
	<p>Solicitation displayed may not include all pertinent data (click to view)</p>
	<p>This is a Fast Award candidate - Quotes \$2,500 or less may be awarded prior to the solicitation return date (as soon as 4 days after issue date)</p>

Review a Solicitation

All RFQs for F

Records 1 thru 48 of 48 Records.

Page: 1

Click on the Solicitation # to view the RFQ & NSN/Part No. to view additional info.

#	NSN/Part No. Nomenclature	Bidset/ Drawings	Spec/ Std	Solicitation #	Auction Status	PR # PR QTY	Issue	Return By
1	4720-00-061-2080 HOSE, AIRDUCT		None	SPM700-04-T-0838 Quote		0010531227 QTY: 2	6/11/2004	06/21/2004
2	4720-00-061-2080 HOSE, AIRDUCT		None	SPM700-04-T-2320 Quote		0010667282 QTY: 1	8/26/2004	09/16/2004
3	4720-00-134-4283 HOSE, AIRDUCT		None	SPM700-05-T-2112 Quote		0010953830 QTY: 3	12/22/2004	01/05/2005
4	4720-00-143-3830 HOSEASSEMBLY, NONMETAL		None	SPM700-05-T-2390 Quote		0010979281 QTY: 16	1/7/2005	01/21/2005
5	4720-00-278-1109 HOSE, NONMETALLIC <i>Mil-Spec</i>	Avail		SPM700-05-T-2237 Quote		0010964818 QTY: 766	12/30/2004	01/13/2005
6	4720-00-278-4890 HOSE, NONMETALLIC. 5/8 <i>Mil-Spec</i>	Avail		SPM760-05-Q-0261 Quote <i>SB</i>		0010895529 QTY: 5423	12/27/2004	01/06/2005
7	4720-00-613-7268 HOSEASSEMBLY, NONME <i>Mil-Spec QPL</i>							
8	4720-00-891-0494 HOSEASSEMBLY, NONMETAL							
9	4720-00-903-0462 HOSEASSEMBLY, NONMETAL	<i>Dwg Avail</i>	None	SPM700-05-T-1883 Quote <i>SB</i>		0010926782 QTY: 53	12/10/2004	12/29/2004
10	4720-00-918-0714 HOSE ASSEMBLY, METALLI <i>QPL</i>		None	SPM760-05-Q-0216 Quote		0010850505 QTY: 5	12/1/2004	12/15/2004

**Note: Each solicitation
will vary to some extent**

REQUEST FOR QUOTATION (THIS IS NOT AN ORDER)

Solicitation

Date Issued

Return by Date

Required Delivery

Purchase Request #

P.O. BOX 16704
COLUMBUS, OH 43215-5010

REQUEST NO.	DATE ISSUED	RETURN BY	DELIVER BY:	PURCHASE REQUEST NUMBER
SPM70004T0838	06/11/04	06/21/04	AWD DT + 219	0010531227

SOLICITATION POC

BUYER CODE	BUYER NAME	BUYER PHONE	BUYER FAX
CMAB4	Tracy McKibben	(614) 692-8146	(614) 693-1555

SOLICITATION POC INFORMATION:

**Buyer Contact Information
(if a buyer has been assigned)**

ASKED QUESTIONS (FAQS) ON BSM DIBBS AT
<https://www.dibbs.bsm.dla.mil/Refs/help/BSMDibbsHelp.htm>
OR PHONE 1-877-DLA-CALL (1-877-352-2255).

DISCREPANCIES FOUND IN BIDSETS SHOULD BE E-MAILED TO
dbi-drawings@dsc.dla.mil

National Stock #

Unit of Issue

Quantity

NSN or Part Number	Unit of Issue	Quantity
4720-00-061-2080	EA	2
Rating	FOB	North American Industry Classification System
		Small Business Size Standard

Department of Defense Priorities and Allocations Manual
<http://www.dtic.mil/whs/directives/corres/html/44001m.htm>

Rating	FOB	North American Industry Classification System	Small Business Size Standard
DOC9	DESTINATION	326220	500

DO: Critical to National Defense
DX: Highest National Defense Urgency
 Helps to ensure that products, materials and services needed for defense are expeditiously available

FORMATION
 AND CONDITIONS SET FORTH IN THE
[AMPLIFIED ACQUISITIONS \(PART13\) JUN2004, REVO2](#)

FORMATION
 ARD. ALL QUOTES MUST BE
 SYSTEM (DIBBS) AT
 R TO RETURN DATE
 ATED FOR AUCTIONING.
 LANCE OF PAYMENTS
 OO.

DESTINATION INSPECTION REQUIRED - FAR 52.246-1 APPLIES.

THIS BUY IS NOT FAST PAY

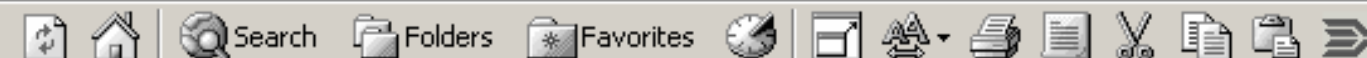

2.bsm.dla.mil/Downloads/RFQ/8/SPM70004T0838.html

Rating	FOB	North American Industry Classification System	Small Business Size Standard
DOC9	DESTINATION	326220	500

QUOTING INFORMATION

FOB point will be "Destination" or "Origin"

CONDITIONS SET FORTH IN THE
[DEFENSE ACQUISITIONS \(PART13\) JUN2004, REVO2](#)

QUOTING INFORMATION

THIS BUY IS A CANDIDATE FOR AUTOMATED AWARD. ALL QUOTES MUST BE SUBMITTED VIA THE DLA INTERNET BID BOARD SYSTEM (DIBBS) AT <https://www.dibbs.bsm.dla.mil>.

QUOTES \$2500 OR LESS MAY BE AWARDED PRIOR TO RETURN DATE UNLESS THIS SOLICITATION HAS BEEN DESIGNATED FOR AUCTIONING.

DFARS 252.225-7001, BUY AMERICAN ACT--BALANCE OF PAYMENTS PROGRAM, APPLIES TO ALL QUOTES ABOVE \$2500.

DESTINATION INSPECTION REQUIRED - FAR 52.246-1 APPLIES.

THIS BUY IS NOT FAST PAY

North American Industry Classification System

<http://www.census.gov/epcd/www/naics.html>

Rating	FOB	North American Industry Classification System	Small Business Size Standard
DOC9	DESTINATION	326220	500

QUOTING INFORMATION

THIS SOLICITATION INCORPORATES THE TERMS AND CONDITIONS OF THE [DLA MASTER SOLICITATION FOR AUTOMATED SIMPLIFIED ACQUISITION](#)

QUOTING INFORMATION

THIS BUY IS A CANDIDATE FOR AUTOMATED AWARD. ALL QUOTES MUST BE SUBMITTED VIA THE DLA INTERNET BID BOARD SYSTEM (DIBBS) AT <https://www.dibbs.bsm.dla.mil>.

QUOTES \$2500 OR LESS MAY BE AWARDED PRIOR TO RETURN DATE UNLESS THIS SOLICITATION HAS BEEN DESIGNATED FOR AUCTIONING.

DFARS 252.225-7001, BUY AMERICAN ACT--BALANCE OF PAYMENTS PROGRAM, APPLIES TO ALL QUOTES ABOVE \$2500.

DESTINATION INSPECTION REQUIRED - FAR 52.246-1 APPLIES.

THIS BUY IS NOT FAST PAY

Maximum # of employees to be considered a "Small" Business

File Edit View Favorites Tools Help

Back Forward Stop Refresh Home Search Folders Favorites Print Copy Paste

Address <http://www.census.gov/epcd/naics02/naicod02.htm>

[33122](#) Rolling and Drawing of Purchased Steel

**North American Industry Classification System
NAICS
<http://www.census.gov/epcd/naics02/naicod02.htm>**

[331311](#) Alumina Refining

[331312](#) Primary Aluminum Production

[331314](#) Secondary Smelting and Alloying of Aluminum

[331315](#) Aluminum Sheet, Plate, and Foil Manufacturing

[331316](#) Aluminum Extruded Product Manufacturing



[331319](#) Other Aluminum Rolling and Drawing

[3314](#) Nonferrous Metal (except Aluminum) Production and Processing

[33141](#) Nonferrous Metal (except Aluminum) Smelting and Refining

[331411](#) Primary Smelting and Refining of Copper

Go to SBA's Website to locate maximum # of Employees

<http://www.sba.gov/size/sizetable2002.html>

Subsector 331 - Primary Metal Manufacturing

EMPLOYEES

331111	Iron and Steel Mills	1,000
331112	Electrometallurgical Ferroalloy Product Manufacturing	750
331210	Iron and Steel Pipe and Tube Manufacturing from Purchased Steel	1,000
331221	Cold-Rolled Steel Shape Manufacturing	1,000
331222	Steel Wire Drawing	1,000
331311	Alumina Refining	1,000
331312	Primary Aluminum Production	1,000
331314	Secondary Smelting and Alloying of Aluminum	750
331315	Aluminum Sheet, Plate and Foil Manufacturing	750
331316	Aluminum Extruded Product Manufacturing	750
331319	Other Aluminum Rolling and Drawing	750
331411	Primary Smelting and Refining of Copper	1,000
331419	Primary Smelting and Refining of Nonferrous Metal (except Copper and Aluminum)	750
331421	Copper Rolling, Drawing and Extruding	750

Maximum # of Employees to be Small





http://dibbs2.bsm.dla.mil/Downloads/RFQ/8/SPM70004T0838.html

Rating	FOB	North American Industry Classification System	Small Business Size Standard
DOC9	DESTINATION	326220	500

QUOTING INFORMATION

THIS SOLICITATION INCORPORATES THE TERMS AND CONDITIONS SET FORTH IN THE [DLA MASTER SOLICITATION FOR AUTOMATED SIMPLIFIED ACQUISITIONS \(PART13\) JUN2004, REVO2](#)

Click on DLA Master Solicitation for clauses & provisions



GENERAL INFORMATION

AWARD. ALL QUOTES MUST BE SUBMITTED TO THE BOARD SYSTEM (DIBBS) AT

PRIOR TO RETURN DATE

UNLESS THIS SOLICITATION HAS BEEN DESIGNATED FOR AUCTIONING.

DFARS 252.225-7001, BUY AMERICAN ACT--BALANCE OF PAYMENTS PROGRAM, APPLIES TO ALL QUOTES ABOVE \$2500.

DESTINATION INSPECTION REQUIRED - FAR 52.246-1 APPLIES.

THIS BUY IS NOT FAST PAY

Master Solicitation (25 page Document)

DEFENSE LOGISTICS AGENCY (DLA) MASTER SOLICITATION FOR AUTOMATED SIMPLIFIED ACQUISITIONS (PART 13)

DECEMBER 2004
REVISION 05

PART I- Instruction to Vendors for the Submission of Quotes and PACE Evaluation:

This solicitation, called the DLA Master Solicitation for Automated Simplified Acquisitions (Part 13) is used for the solicitation of Request for Quotes (RFQ) and the award of Purchase Orders, for automated BSM acquisitions valued up to \$100,000, for each of the Defense Supply Centers: Defense Supply Center Columbus (DSCC), Defense Supply Center Philadelphia (DSCP), and Defense Supply Center Richmond (DSCR). The DLA Solicitation for Automated Simplified Acquisitions (Part 13) is effective in May 2004 with the BSM Retrofit Release.

Effective in May 2004, the DLA Master Solicitation for Automated Simplified Acquisitions (Part 13) is referenced in all RFQs valued up to \$100,000 that are located on the DLA Internet Bid Board System (DIBBS). Each RFQ contains a web link to this solicitation. The DLA DIBBS is separate and distinct from the DSCC DIBBS. Also effective in May 2004, and with this solicitation, is the implementation of the DLA Procurement Automated Contract Evaluation (PACE). DLA PACE is separate and distinct from the PACE programming that is currently implemented at DSCC, DSCP and DSCR.

Vendors are required to read provisions 52.213-9007 and 52.213-9008 of this solicitation to understand the solicitation, evaluation and award process for BSM acquisitions valued up to \$100,000 as of May 2004. Each provision is provided in full text in Part I of this Master Solicitation.

The DLA Master Solicitation for Automated Simplified Acquisitions (Part 13) will be updated from time to time to reflect changes in law, regulation and acquisition policies and procedures. Vendors should not assume that a copy of the DLA Master Solicitation for Automated Simplified Acquisitions (Part 13) once downloaded, will remain effective. Updates to the DLA Master Solicitation for Automated Simplified Acquisitions (Part 13) will be

00C9

DESTINATION

326220

500

QUOTING INFORMATION

THIS SOLICITATION INCORPORATES THE TERMS AND CONDITIONS SET FORTH IN THE [DLA MASTER SOLICITATION FOR AUTOMATED SIMPLIFIED ACQUISITIONS \(PART13\) JUN2004, REVO2](#)

QUOTING INFORMATION

THIS BUY IS A CANDIDATE FOR AUTOMATED AWARD. ALL QUOTES MUST BE SUBMITTED VIA THE DLA INTERNET BID BOARD SYSTEM (DIBBS) AT <https://www.dibbs.bsm.dla.mil>.

QUOTES \$2500 OR LESS MAY BE AWARDED PRIOR TO RETURN DATE UNLESS THIS SOLICITATION HAS BEEN DESIGNATED FOR AUCTIONING

DFARS 252.225-7001, BUY AMERICAN ACT--BALANCE OF PAYMENTS PROGRAM, APPLIES TO ALL QUOTES ABOVE \$2500.

DESTINATION INSPECTION REQUIRED - FAR 52.246-1 APPLIES.

THIS BUY IS NOT FAST PAY

**Applicable
Quoting
Information**

ITEM DESCRIPTION

LINE ITEM 0001

PURCHASE REQUEST	QUANTITY	UNIT OF ISSUE	UNIT PRICE
0010531227	2	EA	

PACKAGING DATA

PREP FOR DELIVERY

PKGING DATA - MIL-STD-2073-1D, 15 DEC 1999

QUP = 001: PRES MTHD = 10: CLNG/DRY = 1: PRESV MAT = 00:

WRAP MAT = 00: CUSH/DUNN MAT = 00: CUSH/DUNN THKNSS = 0:

UNIT CONT = D3: OPI = 0:

PACK CODE = U:

MARKING SHALL BE IN ACCORDANCE WITH MIL-STD-129.

SPECIAL MARKING CODE: 00 - No special marking

PALLETIZATION SHALL BE IN ACCORDANCE WITH MDOO100452 REV A

DATED 04090

For all shipments of packaged materiel to the government, which includes either depot (DLA-direct) or DVD (customer-direct) shipments, both DoD linear and 2-D bar code markings are required on military shipping labels in accordance with MIL-STD-129, revision P, dated December 15, 2002, as amended by Change Notice 1, dated January 15, 2004. 2-D bar coding shall be in accordance with ISO/IEC 15438, ISO/IEC 15434 (ANSI MH10.8.3) and DoD 4500.2-P, MSI linear (code 2 of 2 or code

**Packaging
& Marking
Information**

SHIPPING DATA

PARCEL POST ADDRESS:

W62G2T
XU DEF DIST DEPOT SAN JOAQUIN
TRANSPORTATION OFFICER
PO BOX 960001
STOCKTON CA 95296-0130
US
FREIGHT SHIPPING ADDRESS
W62G2T
XU DEF DIST DEPOT SAN JOAQUIN
25600 S CHRISMAN ROAD
REC WHSE 10 PH 209 839 4307
TRACY CA 95376-5000
US



**Ship To
Information**

NON-MILSTRIP
PROJ



**Procurement History
if it exists**

TYPE	CAGE	CONTRACT NUMBER	QUANTITY	UNIT COST	AWD DATE
STK	OOP11	SPO76000ML733	000003	97.74000	06/12/00



READY TO QUOTE?

All RFQs for FSC Like 4720 sorted by NSN.

Records 1 thru 48 of 48 Records.

Page: 1

Click on the Solicitation # to view the RFQ & NSN/Part No. to view additional info.

#	NSN/Part No. Nomenclature	Bidset/ Drawings	Spec/ Std	Solicitation #	Auction Status	PR # PR QTY	Issue	Return By
1	4720-00-061-2080 HOSE, AIRDUCT		None	SPM700-04-T-0838		0010531227 QTY: 2	6/11/2004	06/21/2004
2	4720-00-061-2080 HOSE, AIRDUCT		None	SPM700-04-T-2320		0010667282 QTY: 1	8/26/2004	09/16/2004
3	4720-00-134-4283 HOSE, AIRDUCT		None	SPM700-05-T-2112		0010953830 QTY: 3	12/22/2004	01/05/2005
4	4720-00-143-3830 HOSEASSEMBLY, NONMETAL		None	SPM700-05-T-2390		0010979281 QTY: 16	1/7/2005	01/21/2005
5	4720-00-278-1109 HOSE, NONMETALLIC Mil-Spec	Avail		SPM700-05-T-2237		0010964818 QTY: 766	12/30/2004	01/13/2005
6	4720-00-278-4890 HOSE, NONMETALLIC. 5/8 Mil-Spec	Avail		SPM760-05-Q-0261 SB		0010895529 QTY: 5423	12/27/2004	01/06/2005
7	4720-00-613-7268 HOSEASSEMBLY, NONME Mil-Spec ORI	Avail		SPM700-05-T-2158		0010956733 QTY: 3	12/27/2004	01/10/2005

QUOTE FORM

Header Data Area

Solicitation#:
SPM70004T0838

Log In CAGE:
DIBBS

Quoting For CAGE:
DIBBS

Display Date/Time: 2/3/2005 3:25:20 PM

Buyer Code:
PMCMAB4

Header Data Area

Bid Type:

BID WITHOUT EXCEPTION

Discount Terms:

1/2% 20 Days

Vendor Quote#: (optional)

Quote Valid for: days.

Accept Packaging? Yes No

Federal Supply Schedule (FSS) / Basic Ordering Agreement (BOA) / Basic Purchase Agreement (BPA)

N/A

FSS BOA BPA Contract #: Expiration Date: (mm-dd-yyyy)

FOB Point

Destination

Origin

City:

State/Province:

Country:

Govt. Inspection Point:

Destination

Origin

Place of Insp - Supplies CAGE:

Place of Insp - Packaging CAGE:

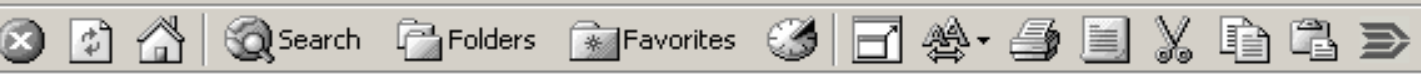

BID TYPE

Bid Without Exception:

Used to indicate that quote is in exact compliance with the solicitation. The following conditions are not considered exceptions:

1. Quoting a different delivery than the required delivery
2. Quoting origin inspection on solicitations requiring destination inspection
3. Quoting a superseding or previously approved part or correction to a cage/part number cited in the AID on an item described by manufacturers CAGE and part number
4. Quoting a used, reconditioned, remanufactured, new/unused Govt. surplus, foreign, or hazardous end item

Header Data Area

Bid Type:
BID WITHOUT EXCEPTION

Vendor Quote#: (optional)

Quote Valid for: 101 days.

Federal Supply Schedule (FSS)
 N/A
 FSS BOA BPA Contract

FOB Point
 Destination
 Origin
City:
Country: --- Select ---

Govt. Inspection Point:
 Destination
 Origin Place of It

SPI Process Proposed: (DFARS)
Are you proposing to use a previously accepted SPI Process? No Yes

Solicitation #

BID TYPE

Header Data Area

Bid Type:

- BID WITHOUT EXCEPTION
- ALTERNATE BID
- BID WITHOUT EXCEPTION
- BID WITH EXCEPTION**
- NO BID

Federal Supply Schedule (FSS)

N/A

FSS BOA BPA Contract

FOB Point

Destination

Origin

City:

Country: --- Select ---

Govt. Inspection Point:

Destination

Origin Place of Interest

Bid With Exception:

The following are considered exceptions:

1. Taking exception to the item description
2. Exceptions to packaging requirements
3. Exceptions to FOB point
4. Quoting destination inspection on a solicitation requiring origin inspection
5. Exceptions to required quantity
6. On automated solicitations (T or U in 9th position of solicitation #), quoting a quantity variance outside the range specified

Quoting Bid With Exception will preclude you from receiving an automated award

BID TYPE**Bid Type:**

- BID WITHOUT EXCEPTION
- ALTERNATE BID
- BID WITHOUT EXCEPTION
- BID WITH EXCEPTION
- NO BID

Federal Supply Schedule

- N/A
- FSS
- BOA
- BPA

FOB Point

- Destination
- Origin

City: State/Province: Country: **Govt. Inspection Point:**

- Destination
- Origin

Place of Insp - Supplies CAGE: Place of Insp - Packaging CAGE:

Alternate Bid:

If you wish to supply other than the approved part, you will have to submit your bid as an Alternate Offer.

For "T" and "U" solicitations, the following applies:

- Offers of alternate products will not be evaluated for the current procurement).
- You may submit a request to the Supply Center for evaluation for future procurements of the same item. The request for evaluation shall cite the National Stock Number (NSN) of the exact product and, as identified in this provision, include the applicable level of technical data on the alternate and exact products

BSM-DIBBS Quote Input Form - Step 1

Display Date/Time: 2/3/2005 3:07:39 PM

Solicitation#:
SPM70004T0838

Log In CAGE:
DIBBS

Quoting For CAGE:
DIBBS

Buyer Code:
PMCMAB4

No Bid:

BID TYPE

- ALTERNATE BID
- BID WITHOUT EXCEPTION
- BID WITH EXCEPTION
- NO BID**

Declining to bid. Quoting zero quantity for all line items will force a bid type of "No Bid." A "No Bid" will also delete a previously submitted bid.

Federal Supply Schedule

- N/A
- FSS
- BOA
- BPA

FOB Point

- Destination
- Origin

City:

State/Province:

Country:

BSM-DIBBS Quote Input Form - Step 1

11:46 PM

Solicitation#: **SPM70004T0838**
Log In CAGE: **DIBBS**

Discount Terms

Header Data Area

Bid Type:

BID WITHOUT

Vendor Quote

Quote Valid

Federal Sup

- N/A
- FSS
- E

FOB Point

- Destination
 - Origin
- City: _____
Country: _____

Govt. Inspe

- Destination
 - Origin
- Place of Insp - supplies CAGE: _____
Place of Insp - Packaging CAGE: _____

Select from list of the 6 most common discount terms

Default: Discount Terms from Vendor DIBBS Registration

Discount Terms:

- Net 30
- Net 30**
- 2% 10 Days
- 1/2% 20 Days
- 1/2% 10 Days
- 1/4% 20 Days
- Net 10 Days



SPI Process Proposed: (DFARS 252.211-7005) (applicable to quotes total value greater than \$2500)

Are you proposing to use a previously accepted SPI Process? No Yes

BSM-DIBBS Quote Input Form - Step 1

Solicitation#: **SPM70004T0838** Log In CAGE: **DIBBS** Quoting For CAGE: **DIBBS** Display Date/Time: 2/3/2005 4:11:46 PM
 Buyer Code: **PMCMAB4**

Header Data Area

Bid Type:
 BID WITHOUT EXCEPTION

Vendor Quote#: (optional) **13972-05**

Quote Valid for: **101** days.

Federal Supply Schedule (FSS) / Basic Ordering Agreement
 N/A
 FSS BOA BPA Contract #:

FOB Point
 Destination
 Origin
 City: State/Province: --- Select ---
 Country: --- Select ---

Govt. Inspection Point:
 Destination
 Origin Place of Insp - Supplies CAGE: Place of Insp - Packaging CAGE:

SPI Process Proposed: (DFARS 252.211-7005) (applicable to quotes total value greater than \$2500)
 Are you proposing to use a previously accepted SPI Process? No Yes

Vendor Quote Number Optional Fill-in for Vendor Reference Only



BSM-DIBBS Quote Input Form - Step 1

Display Date/Time: 2/3/2005 4:11:46 PM

Solicitation#: **SPM70004T0838**

Log In CAGE: **DIBBS**

Quoting For CAGE: **DIBBS**

Buyer Code: **PMCMAB4**

Header Data Area

Quote Valid For ?
Enter Number Of Days
Your Quote Is Valid.
Default: Quote Valid Days
from Registration
Validation: Forces numeric
response from 1 - 999

Bid Type:

BID WITHOUT EXCEPTION

Vendor Quote#: (optional)

Quote Valid for: 101 days.

Federal Supply Schedule (FSS) /

- N/A
- FSS
- BOA
- BPA Contract

FOB Point

- Destination
- Origin

City:

State/Province: --- Select ---

Country: --- Select ---

Govt. Inspection Point:

- Destination
- Origin

Place of Insp - Supplies CAGE:

Place of Insp - Packaging CAGE:

SPI Process Proposed: (DFARS 252.211-7005) (applicable to quotes total value greater than \$2500)

Are you proposing to use a previously accepted SPI Process? No Yes

BSM-DIBBS Quote Input Form - Step 1

Solicitation#: **SPM70004T0838** Log In CAGE: **DIBBS** Quoting For CAGE: **DIBBS** Display Date/Time: 2/3/2005 4:11:46 PM
 Buyer Code: **PMCMAB4**

Header Data Area

Bid Type: **Discount Terms:**

Vendor Quote#: (optional)

Quote Valid for: days. **Accept Packaging?** Yes No

Federal Supply Schedule (FSS) / Basic Ordering Agreement (BOA) / Basic Purchase Agreement (BPA)

N/A FSS BOA BPA Contract

FOB Point

Destination

Origin

City:

Country:

Govt. Inspection Point:

Destination Place of Insp - supplies CAGE:

Origin Place of Insp - Packaging CAGE:

SPI Process Proposed: (DFARS 252.211-7005) (applicable to quotes total value greater than \$2500)

Are you proposing to use a previously accepted SPI Process? No Yes

Accept Packaging?
 Select Appropriate Response
 If "No," Bid Type Must Equal
 "Bid with Exception" or
 "Alternate Bid"

**Federal Supply Schedule (FSS)
Basic Ordering Agreement (BOA)
Basic Purchase Agreement (BPA)
Select "FSS/BOA/BPA" if applicable and
include Contract # and expiration date**

Quote Valid for: 101 days. **Accept Packaging?** Yes No

Federal Supply Schedule (FSS) / Basic Ordering Agreement (BOA) / Basic Purchase Agreement (BPA)
 N/A
 FSS BOA BPA Contract #: Expiration Date: (mm-dd-yyyy)

FOB Point
 Destination
 Origin
City: State/Province: --- Select ---
Country: --- Select ---

Govt. Inspection Point:
 Destination
 Origin Place of Insp - Supplies CAGE: Place of Insp - Packaging CAGE:

SPI Process Proposed: (DFARS 252.211-7005) (applicable to quotes total value greater than \$2500)
Are you proposing to use a previously accepted SPI Process? No Yes

FOB (Free On Board) Point

Select "Destination/Origin" for FOB point

Default: RFQ Requirement

- If not in accordance with RFQ requirement, bid type must equal "Bid with Exception" or "Alternate Bid"
- FoB Origin requires entries for City, State or Province, and Country

FSS PA Contract #: Expiration Date: (mm-dd-yyyy)

FOB Point

Destination

Origin

City: State/Province: --- Select ---

Country: --- Select ---

Govt. Inspection Point:

Destination

Origin Place of Insp - Supplies CAGE: Place of Insp - Packaging CAGE:

SPI Process Proposed: (DFARS 252.211-7005) (applicable to quotes total value greater than \$2500)

Are you proposing to use a previously accepted SPI Process? No Yes

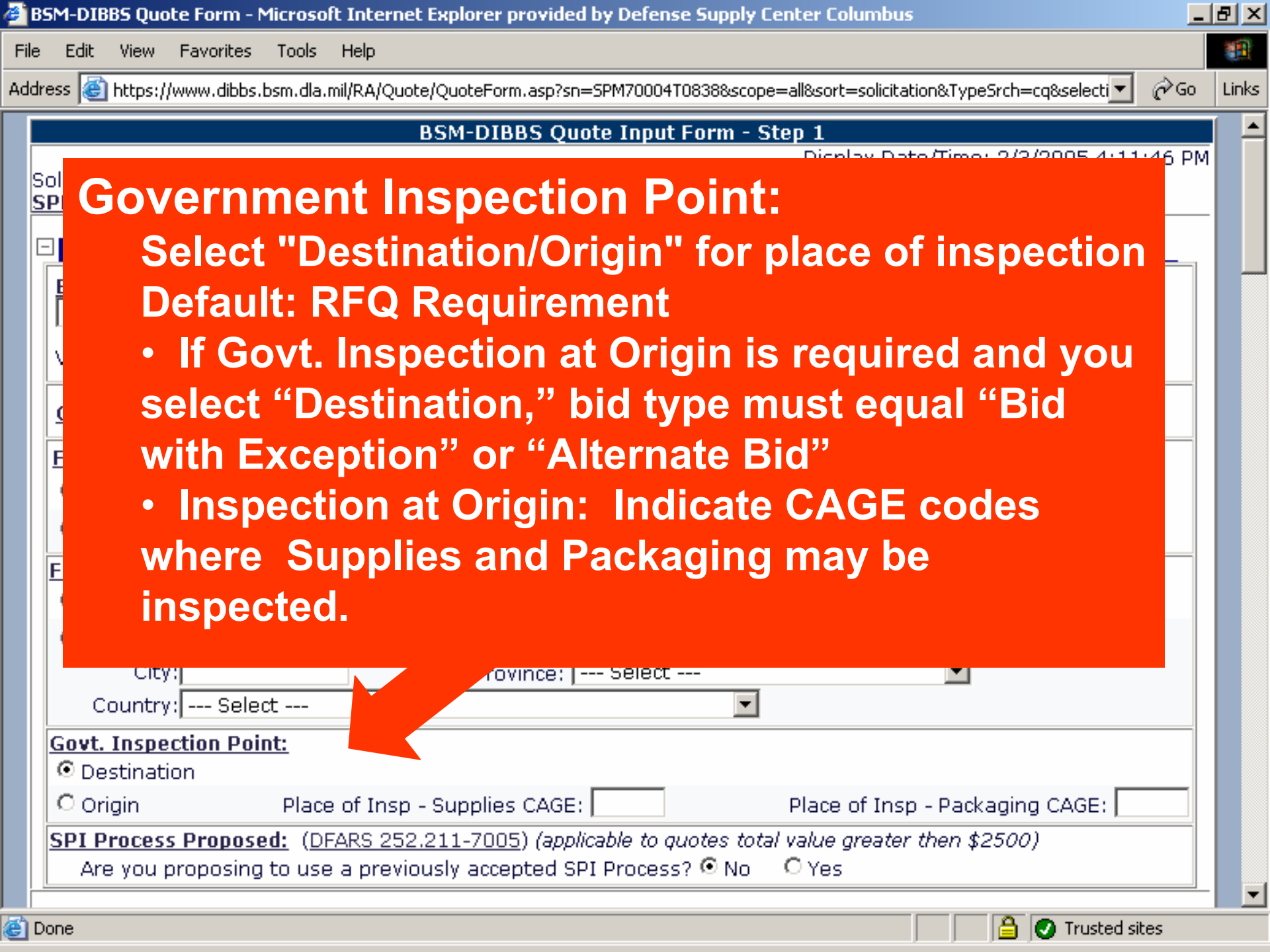

Government Inspection Point:

Select "Destination/Origin" for place of inspection
Default: RFQ Requirement

- If Govt. Inspection at Origin is required and you select "Destination," bid type must equal "Bid with Exception" or "Alternate Bid"
- Inspection at Origin: Indicate CAGE codes where Supplies and Packaging may be inspected.

Govt. Inspection Point:

Destination

Origin

Place of Insp - Supplies CAGE:

Place of Insp - Packaging CAGE:

SPI Process Proposed: (DFARS 252.211-7005) (applicable to quotes total value greater than \$2500)

Are you proposing to use a previously accepted SPI Process? No Yes

Solicitation#: SPM70004T0838	Log In CAGE: DIBBS	Quoting For CAGE: DIBBS	Display Date/Time: 2/3/2005 4:11:46 PM
			Buyer Code: PMCMAB4

Header Data Area

Bid Type: Discount Terms:

Vendor Quote#: (optional)

SPI Process Proposed

Applies only if quote is over \$2500

Used to propose a management or manufacturing process that has been accepted previously by the Department of Defense under the Single Process Initiative (SPI) for use in lieu of specific military or Federal specification or standard at specific facilities.

Origin Place of Insp - Supplies CAGE: Place of Insp - Packaging CAGE:

SPI Process Proposed: (DFARS 252.211-7005) (applicable to quotes total value greater than \$2500)

Are you proposing to use a previously accepted SPI Process? No Yes

QUOTE FORM Price Data Area

Price Data Area

Pricing & Delivery

NSN/Part #:4720000612080

LINE # / PR #	QUANTITY	UI	UNIT PRICE	DELIVERY DAYS
0001 0010531227	2	EA		

Minimum Order Quantity

Is [] quantity obtainable to store additional total price of [] minimum [] quantity []

Pricing & Delivery:

- Enter price and delivery days by line item.
- If quantity quoted not in accordance with RFQ, bid type must be "Bid with Exception" or "Alternate Bid."
- If price/delivery do not vary by line, use the "cascade fill" to enter first line unit price and delivery values and "cascade" for all line items.
- Delivery Default: RFQ requirement

5		to		
6		to		

Clear Values

Price Data Area

Pricing & Delivery

NSN/Part #: **4720000612080** NOMEN:HOSE,AIRDUCT

LINE # / PR #	QUANTITY	UI	UNIT PRICE	DELIVERY DAYS
0001 0010531227	2	EA		

BSM-DIBBS Quote Form - Microsoft Internet Explorer provided by Defense Supply Center Columbus

File Edit View Favorites Tools Help

Back Forward Stop Home Search Folders Favorites

Address: <https://www.dibbs.bsm.dla.mil/RA/Quote/QuoteForm.asp?sn=SPM70005T2241&TypeSrch=cq&selection=fsc&value=2040%2C20> Go Links

Price Data Area

Pricing & Delivery

NSN/Part #: **2090003512299** NOMEN:

LINE # / PR #	QUANTITY	UI	UNIT PRICE	DELIVERY DAYS
0001 0010964811	21	EA		cascade fill ▼
0002 0010964811	32	EA		

Minimum Order Quantity
Is a larger quantity obtainable at no additional total price due to a minimum order quantity?
NSN/PN: **2090003512299** No Yes Qty:

Quantity Variance
NSN/PN: **2090003512299** + - %

Quantity Available for Immediate Shipment
Is there a quantity available for immediate shipment?
NSN/PN: **2090003512299** No Yes Qty: Unit Price: DLVY Days:

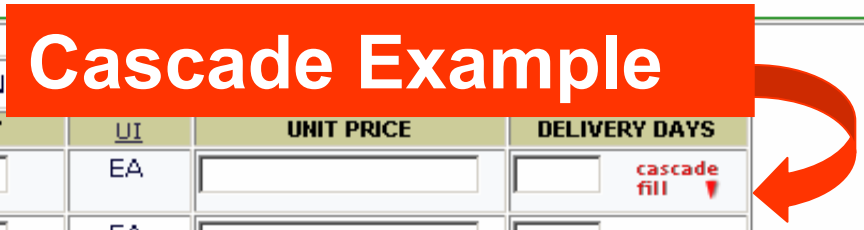

Price Data Area

Pricing & Delivery

NSN/Part #:4720000612080 NOMEN:HOSE,AIRDUCT

LINE # / PR #	QUANTITY	UI	UNIT PRICE	DELIVERY DAYS
0001 0010531227	2	EA		

Minimum Order Quantity

Is a larger quantity obtainable at no additional total price due to a minimum order quantity?

NSN/PN: 4720000612080 No Yes Qty:

Quantity Variance

Minimum Order Quantity

- Select "no or yes" in response to question, "Is a larger quantity obtainable at no additional total price due to a minimum order quantity?"
- Yes, requires an entry for the quantity obtainable at no additional total price.

5		to	
6		to	

Pricing & Delivery

NSN/Part #: 4720000612080 NOMEN:HOSE,AIRDUCT

LINE # / PR #	QUANTITY	UI	UNIT PRICE	DELIVERY DAYS
0001 0010531227	2	EA		

Minimum Order Quantity

Is a larger quantity obtainable at no additional total price due to a minimum order quantity?

NSN/PN: 4720000612080 No Yes Qty: **Quantity Variance**NSN/PN: 4720000612080 + - %

Quantity Variance

- Default: + 0% - 0%
- On automated solicitations (“T” or “U” in the 9th position of the solicitation #), if a quantity variance is quoted when not allowed by the solicitation, or is outside what is allowed, bid type must be “Bid with Exception” or “Alternate Bid”

[Clear Values](#)**Product Offered Representations**

• NSN/Part #: 4720000612080 - HOSE,AIRDUCT

Price Data Area

Pricing & Delivery

Quantity Available for Immediate Shipment

- Select "no or yes" in response to question, "Is there a quantity available for immediate shipment?"
- Yes, requires an entry for the quantity available for immediate shipment, unit price, and delivery days



Quantity Available for Immediate Shipment

Is there a quantity available for immediate shipment?

NSN/PN: **4720000612080** No Yes Qty: Unit Price: DLVY Days:

Price Break Ranges (DLAD 52.213-9000)

NSN: **4720000612080**

Enter only numeric values. DO NOT enter + or -

Range	QTY Range		Unit Price
1	<input type="text"/>	to <input type="text"/>	<input type="text"/>
2	<input type="text"/>	to <input type="text"/>	<input type="text"/>
3	<input type="text"/>	to <input type="text"/>	<input type="text"/>
4	<input type="text"/>	to <input type="text"/>	<input type="text"/>
5	<input type="text"/>	to <input type="text"/>	<input type="text"/>
6	<input type="text"/>	to <input type="text"/>	<input type="text"/>

Clear Values

Price Data Area

Pricing & Delivery

NSN/Part #:4720000612080 NOMEN:HOSE,AIRDUCT

LINE # / PR #	QUANTITY	LIT	UNIT PRICE	DELIVERY DAYS
---------------	----------	-----	------------	---------------

Price Break Ranges

- Enter price break ranges and unit prices in the blocks provided
- On solicited price break ranges, if any, defaults to RFQ requirement; ranges may be altered using "Clear Values" link. If price break ranges are not solicited, no default values.

NSN: 4720000612080

Enter only numeric values. DO NOT enter + or -

Range	QTY Range		Unit Price
1	<input type="text"/>	to <input type="text"/>	<input type="text"/>
2	<input type="text"/>	to <input type="text"/>	<input type="text"/>
3	<input type="text"/>	to <input type="text"/>	<input type="text"/>
4	<input type="text"/>	to <input type="text"/>	<input type="text"/>
5	<input type="text"/>	to <input type="text"/>	<input type="text"/>
6	<input type="text"/>	to <input type="text"/>	<input type="text"/>

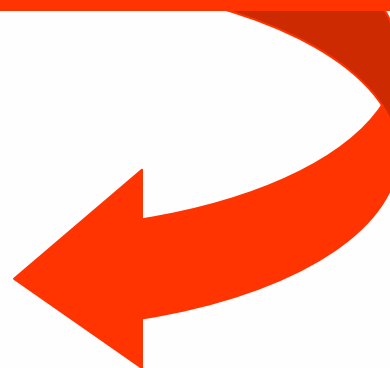
[Clear Values](#)

QUOTE FORM
Products Offered
Representations
Area

Product Offered Representations

• NSN/Part #: **4720000612080** - HOSE,AIRDUCT

Part Number Offered

- Exact Product
- Alternate Product
CAGE: PN:
- Superceding P/N
CAGE: PN:
Reason:
- Previously-Approved Product
CAGE: PN:
(Enter Contract/Solicitation Number in Remarks)
- Correction to CAGE/P/N Cited in AID
CAGE: PN:
Reason:

Manufacturer/Dealer

Select the status of the "Quote for" CAGE Code:

Material Requirements: (FAR 52.211-5)

Used, Reconditioned, Remanufactured, or New/Unused Government Surplus?

- No
- Yes

■ NSN/Part #: 4720000612080 - HOSE,AIRDUCT

Part Number Offered

Exact Product

Alternate Prod (96169) 75765-55X1PC9
CAGE: PN:

Superceding P/N
CAGE: PN:
Reason:

Previously-Approved Product
CAGE: PN:
(Enter Contract/Solicitation Number in Remarks)

Correction to CAGE/P/N Cited in AID
CAGE: PN:
Reason:

There are two different situations that apply to “Part Number Offered”:

1. Applies when approved manufacturing source or sources are specified on a drawing
2. Applies to Items Described by Approved Source CAGE(s) and Corresponding Part Number(s)

Manufacturer/Dealer

**Manufacturer / Dealer:
Select Status of
“Quote for” CAGE**

- Dealer
- Manufacturer
- Qualified Supplier
Listed Dealer
- Qualified Supplier
Listed Manufacturer

--- Select ---
--- Select ---
DEALER
MANUFACTURER
QUALIFIED SUPPLIER LIST DEALER
QUALIFIED SUPPLIER LIST MANUFACTURER

Safety Data: (FAR 52.223-3)

Under any resultant contract as prescribed by FAR 52.223-3.

(DFARS 252.223-7001):

Program Certification (DFARS 252.225-7035)

for Supplies Acquired for use Outside the United States)

Duty Free Entry Requested NO YES

(Not available for Supplies Acquired for use Outside the United States)

Certification Regarding Knowledge of Child Labor for Listed End Products (FAR 52.222-18)

Are you providing an end product that may have been mined, produced or manufactured by forced or indentured child labor? (See the Department of Labor’s current list of products and corresponding countries at <http://www.dol.gov/ILAB/regqs/eo13126/main.htm>)

NO

(Enter Contract/Solicitation Number in Remarks)

Correction to CAGE/P/N Cited in AID
CAGE: PN:
Reason:

Manufacturer/Dealer

Select the status of the "Quote for" CAGE Code:
Actual Manufacturing/Production Source CAGE:

If CAGE is Unknown, enter Name and address:

**If CAGE unknown,
Enter Name & Address**

Material Requirements: (FAR 52.211-5)

Used, Reconditioned, Remanufactured, or New/Unused Government Surplus?

No Yes

Hazardous Material Identification and Material Safety Data: (FAR 52.223-3)

Identify hazardous material to be delivered under any resultant contract as prescribed by FAR 52.223-3. Hazardous Material?

No Yes Hazardous Warning Labels (DFARS 252.223-7001):

Buy American Act - Balance of Payments Program Certification (DFARS 252.225-7035)

(Information Only for Quotes \$2500 or less and for Supplies Acquired for use Outside the United States)

Domestic End Product
 Qualifying Country End Product
 Non-Qualifying Country End Product
Country of Origin (if known):

Duty Free Entry Requested No Yes

(Not available for Supplies Acquired for use Outside the United States)

Certification Regarding Knowledge of Child Labor for Listed End Products (FAR 52.222-18)

Manufacturer/Dealer

Select the status of the "Quote for" CAGE Code:

Material Requirements: (FAR 52.211-5)

Used, Reconditioned, Remanufactured, or New/Unused Government Surplus?

No Yes

- Type of Material
- Used
- Reconditioned
- Remanufactured
- New/Unused Govt. Surplus
- Select ---

Hazardous Material

Identify hazardous material.
Hazardous Material:
 No Yes

Buy American Act - Balance of Payments Program

(Information Only for Quotes \$2500 or less and for Supplies)

- Domestic End Product
- Qualifying Country End Product
- Non-Qualifying Country End Product

Country of Origin (if known):

Duty Free Entry Requested No Yes

(Not available for Supplies Acquired for use Outside the U.S.)

Certification Regarding Knowledge of Child Labor for Listed End Products (FAR 52.222-18)

Are you providing an end product that may have been mined, produced or manufactured by forced or indentured child labor? (See the Department of Labor's current list of products and corresponding countries at <http://www.dol.gov/ILAB/regs/eo13126/main.htm>)

**Material Requirements:
Select Appropriate
Description:**

- Used
- Reconditioned
- Remanufactured
- New / Unused
Govt Surplus

Manufacturer/Dealer

Select the status of the "Quote for" CAGE Code:

Material Requirements: (FAR 52.211-5)

Used, Reconditioned, Remanufactured, or New/Unused Government Surplus?

No Yes

Hazardous Material Identification and Material Safety Data: (FAR 52.223-3)

Identify hazardous material to be delivered under any resultant contract as prescribed by FAR 52.223-3. Hazardous Material?

No Yes

- Select ---
- HAZARDOUS COMMUNICATION STANDARD
- FEDERAL INSECTICIDE, FUNGICIDE AND RODENTICIDE ACT
- FEDERAL FOOD, DRUG, AND COSMETIC ACT
- CONSUMER PRODUCT SAFETY ACT
- FEDERAL HAZARDOUS SUBSTANCE ACT
- FEDERAL ALCOHOL ADMINISTRATION ACT

Buy American Act

(Information Only)

- Domestic End Product
- Qualifying Country of Origin
- Non-Qualifying Country of Origin

Country of Origin (if known):

Duty Free Entry Requested No Yes

(Not available for Supplies Acquired for use Outside the United States)

Certification Regarding Knowledge of Child Labor for Listed End Products

Are you providing an end product that may have been mined, produced, or otherwise processed by indentured child labor? (See the Department of Labor's current list of countries at <http://www.dol.gov/ILAB/reqs/eo13126/main.htm>)

Contractor Representations

Taxpayer Identification Number (TIN): FAR 52.204-3 & FAR 52.212-3(b)

TIN:

or Status:

Type of Organization:

**Hazardous Material Identification and Material Safety Data:
Select Appropriate Description**

Hazardous Material Identification and Material Safety Data: (FAR 52.223-3)

Identify hazardous material to be delivered under any resultant contract as prescribed by FAR 52.223-3.
Hazardous Material?

No Yes

Hazardous Warning Labels (DFARS 252.223-7001):

--- Select ---

Buy American Act - Balance of Payments Program Certification (DFARS 252.223-7001)

(Information Only for Quotes \$2500 or less and for Supplies Acquired for use in the United States)

Domestic End Product

Qualifying Country End Product

--- Select ---

Non-Qualifying Country End Product

Country of Origin (if known):

Duty Free Entry Requested No Yes

(Not available for Supplies Acquired for use Outside the United States)

Certification Regarding Knowledge of Child Labor for Listed End Products

Are you providing an end product that may have been mined, produced, or processed by indentured child labor? (See the Department of Labor's current list of products and corresponding countries at <http://www.dol.gov/ILAB/regs/eo13126/main.htm>)

NO

Select one:

- Domestic End Product
- Qualifying Country End Products (from picklist of countries)
- Non-qualifying Country End Products (fill-in country name, if known)

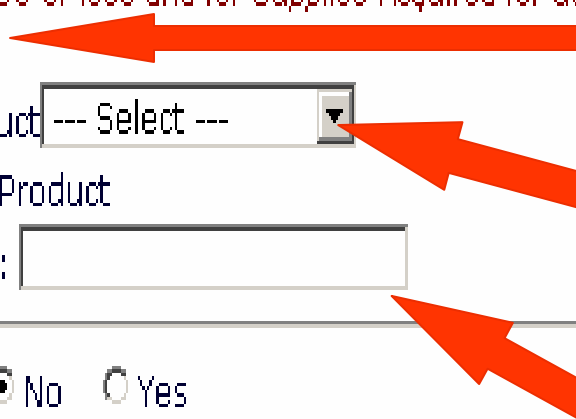

Hazardous Material Identification and Material Safety Data: (FAR 52.223-3)

Identify hazardous material to be delivered under any resultant contract as prescribed by FAR 52.223-3. Hazardous Material?

No Yes Hazardous Warning Labels (DFARS 252.223-7001):
--- Select ---

Buy American Act - Balance of Payments Program Certification (DFARS 252.225-7035)

(Information Only for Quotes \$2500 or less and for Supplies Acquired for use Outside the United States)

Domestic End Product
 Qualifying Country End Product --- Select ---
 Non-Qualifying Country End Product
Country of Origin (if known): KOREA

Duty Free Entry Requested No Yes

(Not available for Supplies Acquired for use Outside the United States)

Certification Regarding Knowledge of Child Labor for Listed End Products

Are you providing an end product that may have been mined, produced, or manufactured wholly or in part by indentured child labor? (See the Department of Labor's current list of countries at <http://www.dol.gov/ILAB/regs/eo13126/main.htm>)

NO

Select "yes" if duty free entry is requested and then answer: (1) Are such foreign supplies now in the United States?" and (2) Has the duty on such foreign supplies been paid?

Contractor Representations

Taxpayer Identification Number (TIN): FAR 52.204-3 & FAR 52.212-3(b)

Hazardous Material Identification and Material Safety Data: (FAR 52.223-3)

Identify hazardous material to be delivered under any resultant contract as prescribed by FAR 52.223-3.
Hazardous Material?

- No Yes

Hazardous Warning Labels (DFARS 252.223-7001):

--- Select ---

Buy American Act - Balance of Payments Program Certification (DFARS 252.225-7035)

(Information Only for Quotes \$2500 or less and for Supplies Acquired for use Outside the United States)

- Domestic End Product
 Qualifying Country End Product
 Non-Qualifying Country End Product

--- Select ---

Country of Origin (if known): KOREA

Applies to quotes of \$2,500 or less

(Information available for Supplies Acquired for use Outside the United States)

Certification Regarding Knowledge of Child Labor for Listed End Products (FAR 52.222-18)

Are you providing an end product that may have been mined, produced or manufactured by forced or indentured child labor? (See the Department of Labor's current list of products and corresponding countries at <http://www.dol.gov/ILAB/regs/eo13126/main.htm>)

NO

NO

MAY SUPPLY, BUT NOT AWARE OF ANY SUCH USE OF CHILD LABOR BASED ON GOOD FAITH EFFORT.

CANNOT CERTIFY

Taxpayer Identification Number (TIN): FAR 52.204-3 & FAR 52.212-3(b)

TIN:

or Status: Agency or Instrumentality of Foreign Govt.

Type of Organization: International organization per 26 CFR 1.6049-4

Common Parent:

Contractor Representations

Contractor Representations

Taxpayer Identification Number (TIN): [FAR 52.204-3](#) & [FAR 52.212-3\(b\)](#)

TIN:

Supply
Taxpayer ID #
(TIN)

or Status:

Type of Organization:

Common Parent:

Name:

TIN:

NA:

Small Business and Other Business Type Representations - [FAR 52.219-1](#) & [FAR 52.212-3\(c\)](#)

Business Type:

If Small Business, select one or more from the following if applicable:

Small Disadvantaged Business:

Woman-Owned Small Business:

Veteran-Owned Small Business:

HUBZone Small Business:

HUBZone Joint Venture that complies with 13 CFR Part 26:

Very Small Business:

If HUBZone Joint Venture, enter CAGE(s)/Name(s) of the participating HUBZone small business concern (s):

If Small Disadvantaged Business (SDB), complete the following:

SDB Designated Group:

Contractor Representations

Taxpayer Identification Number (TIN): [FAR 52.204-3](#) & [FAR 52.212-3\(b\)](#)

TIN:

or Status:

**or Supply
TIN Status**

Type of O

Tin Applied For

Common

- Agency or Instrumentality of Foreign Govt.
- Non-resident Alien, Foreign Corp, Foreign Corp., Foreign Partnership
- Agency or Instrumentality of Federal Govt.

NA:

Small Business and Other Business Type Representations - [FAR 52.219-1](#) & [FAR 52.212-3\(c\)](#)

Business Type:

If Small Business, select one or more from the following if applicable:

Small Disadvantaged Business:

Woman-Owned Small Business:

Veteran-Owned Small Business:

HUBZone Small Business:

HUBZone Joint Venture that complies with 13 CFR Part 26:

Very Small Business:

If HUBZone Joint Venture, enter CAGE(s)/Name(s) of the participating HUBZone small business concern (s):

Contractor Representat

Taxpayer Identification Number (TIN): FAR

TIN:

or Status: Agency or Instrumentality of

Type of Organization:

Common Parent:

Name:

NA:

**Select
Type of Organization**

- Select ---
- Sole proprietorship
- Partnership
- Corporate entity (not tax-exempt)
- Corporate entity (tax-exempt)
- Government entity (Federal, State, or local)
- Foreign government
- International organization per 26 CFR 1.6049-4

Small Business and O [18 & FAR 52.212-3\(c\)](#)

Business Type:

If Small Business, select one or more from the following if applicable:

Small Disadvantaged Business:

Woman-Owned Small Business:

Veteran-Owned Small Business:

HUBZone Small Business:

HUBZone Joint Venture that complies with 13 CFR Part 26:

Very Small Business:

If HUBZone Joint Venture, enter CAGE(s)/Name(s) of the participating HUBZone small business concern (s):

If Small Disadvantaged Business (SDB), complete the following:

Contractor Representations

Taxpayer Identification Number (TIN): FAR

TIN:

or Status: Agency or Instrumentality of F

Type of Organization: --- Select ---

**List Parent Company,
if any**

Common Parent:

Name:

TIN:

NA:

Small Business and Other Business Type Representations - FAR 52.219-1 & FAR 52.212-3(c)

Business Type: Small Business

If Small Business, select one or more from the following if applicable:

Small Disadvantaged Business:

Woman-Owned Small Business:

Veteran-Owned Small Business: Service Disabled Veteran-Owned Small Business

HUBZone Small Business:

HUBZone Joint Venture that complies with 13 CFR Part 26:

Very Small Business: --- Select ---

If HUBZone Joint Venture, enter CAGE(s)/Name(s) of the participating HUBZone small business concern (s):

If Small Disadvantaged Business (SDB), complete the following:

SDB Designated Group: Other SDB Certified or Determined by SBA

Contractor Representations

Taxpayer Identification Number (TIN): [FAR 52.204-3](#) & [FAR 52.212-3\(b\)](#)

TIN:

or Status:

Type of Organization:

Common Parent:

Name:

TIN:

NA:



Small Business and Other Business

Business Type:

Small Business

--- Select ---

If Small Business:

- Small Business
- JWOD Participating Nonprofit Agency
- Nonprofit Institution
- Historically Black College or University (HBCU)
- Minority Institution (other than HBCU)
- Educational Institution (other than HBCU or Minority)
- Intragovernmental
- Large Business/Other Business

Small Disadvantaged Business:

Woman-Owned Business:

Veteran-Owned Business:

HUBZone Small Business:

HUBZone Joint Venture that complies with 13 CFR Part 26:

Very Small Business:

If HUBZone Joint Venture, enter CAGE(s)/Name(s) of the participating HUBZone small business concern (s):

If Small Disadvantaged Business (SDB), complete the following:

SDB Designated Group:

Contractor Representations

Taxpayer Identification Number (TIN): FAR 52.204-3 & FAR 52.212-3(b)

TIN:

or Status: Agency or Instrumentality of Foreign Govt.

Type of Organization: International organization per 26 CFR 1.6049-4

Common Parent:

Name:

NA: DSCC

**Small Businesses:
Select Applicable
Descriptions**

Small Business and Other Business Ty

Business Type: Small Business

If Small Business, select one or more from the following if applicable:

Small Disadvantaged Business:

Woman-Owned Small Business:

Veteran-Owned Small Business: Service Disabled Veteran-Owned Small Business

HUBZone Small Business:

HUBZone Joint Venture that complies with 13 CFR Part 26:

Very Small Business: --- Select ---

If HUBZone Joint Venture, enter CAGE(s)/Name(s) of the participating HUBZone small business concern (s):

If Small Disadvantaged Business (SDB), complete the following:

SDB Designated Group: Other SDB Certified or Determined by SBA

Affirmative Action Compliance FAR 52.222-25 & FAR 52.212-3(d)(3)

No Previous Contracts Subject to Requirements

Contractor Representations

Taxpayer Identification Number (TIN): FAR 52.204-3 & FAR 52.212-3(b)
 TIN:
 or Status: Agency or Instrumentality of Foreign Govt.
 Type of Organization: International organization per 26 CFR 1.6049-4
 Common Parent:
 Name: TIN:
 NA: DSCC 01111111

Small Business and Other Business Type

Business Type: Small Business

If Small Business, select one or more applicable descriptions:

Small Disadvantaged Business:
 Woman-Owned Small Business:
 Veteran-Owned Small Business: Service Disabled Veteran-Owned Small Business
 HUBZone Small Business:
 HUBZone Joint Venture that complies with 13 CFR Part 26:
 Very Small Business: --- Select ---

If HUBZone Joint Venture, enter CAGE(s)/Name(s) of the participating HUBZone small business concern (s):

If Small Disadvantaged Business (SDB), complete the following:
 SDB Designated Group: Other SDB Certified or Determined by SBA

**Small Businesses:
Select Applicable
Descriptions**

Affirmative Action Compliance FAR 52.222-25 & FAR 52.212-3(d)(3)

Contractor Representations

Taxpayer Identification Number (TIN): [FAR 52.204-3](#) & [FAR 52.212-3\(b\)](#)

TIN:

or Status: ▼

Type of Organization: ▼

Common Parent:

Name:

TIN:

NA:

**Small Businesses:
Select Applicable
Descriptions**

Small Business and Other Business Type Requirements

Business Type:

If Small Business, select one or more from

Small Disadvantaged Business:

Woman-Owned Small Business:

Veteran-Owned Small Business: ▼

- Select ---
- Service Disabled Veteran-Owned Small Business
- Other Veteran-Owned Small Business

HUBZone Small Business:

HUBZone Joint Venture that complies with 13 CFR Part 26:

Very Small Business: ▼

If HUBZone Joint Venture, enter CAGE(s)/Name(s) of the participating HUBZone small business concern (s):

If Small Disadvantaged Business (SDB), complete the following:

SDB Designated Group: ▼

Contractor Representations

Taxpayer Identification Number (TIN): [FAR 52.204-3](#) & [FAR 52.212-3\(b\)](#)
 TIN:
 or Status:
 Type of Organization:
 Common Parent:
 Name: TIN:
 NA:

Small Business and Other Business Type Representations - [FAR 52.219-1](#) & [FAR 52.212-3\(c\)](#)

Business Type:

If Small Business, select one or more:

Small Disadvantaged Business:
 Woman-Owned Small Business:
 Veteran-Owned Small Business:
 HUBZone Small Business:
 HUBZone Joint Venture that complies with 13 CFR Part 26:
 Very Small Business:

If HUBZone Joint Venture, enter CAGE(s)/Name(s) of the participating HUBZone small business concern (s):

If Small Disadvantaged Business (SDB), complete the following:
 SDB Designated Group:

**Small Businesses:
Select Applicable
Descriptions**

Affirmative Action Compliance [FAR 52.222-25](#) & [FAR 52.212-3\(d\)\(3\)](#)

Contractor Representations

Taxpayer Identification Number (TIN): [FAR 52.204-3](#) & [FAR 52.212-3\(b\)](#)

TIN:

or Status:

Type of Organization:

Common Parent:

Name:

TIN:

NA:

Small Business and Other Business Type Representations - [FAR 52.219-1](#) & [FAR 52.212-3\(c\)](#)

Business Type:

If Small Business, select one or more from:

Small Disadvantaged Business:

Woman-Owned Small Business:

Veteran-Owned Small Business:

HUBZone Small Business:

HUBZone Joint Venture that complies with 13 CFR Part 26:

Very Small Business:

If HUBZone Joint Venture (s):

HUBZone small business concern

If Small Disadvantaged Business (SDB), complete the following:

SDB Designated Group:

Affirmative Action Compliance [FAR 52.222-25](#) & [FAR 52.212-3\(d\)\(3\)](#)

No Previous Contracts Subject to Requirements



Contractor Representations

Taxpayer Identification Number (TIN): [FAR 52.204-3](#) & [FAR 52.212-3\(b\)](#)
TIN:
or Status:
Type of Organization:
Common Parent:
Name: TIN:
NA:

Small Business and Other Business Type Representations - [FAR 52.219-1](#) & [FAR 52.212-3\(c\)](#)

Business Type:

If Small Business, select one or more from the following if applicable:

- Small Disadvantaged Business:
- Woman-Owned Small Business:
- Veteran-Owned Small Business:
- HUBZone Small Business:
- HUBZone Joint Venture that complies with FAR 52.219-1:
- Very Small Business:

**HUBZone Joint Ventures
Provide CAGE(s) and
Name(s)**

If HUBZone Joint Venture, enter CAGE(s)/Name(s) of the participating HUBZone small business concern (s):

If Small Disadvantaged Business (SDB), complete the following:
SDB Designated Group:

Affirmative Action Compliance [FAR 52.222-25](#) & [FAR 52.212-3\(d\)\(3\)](#)

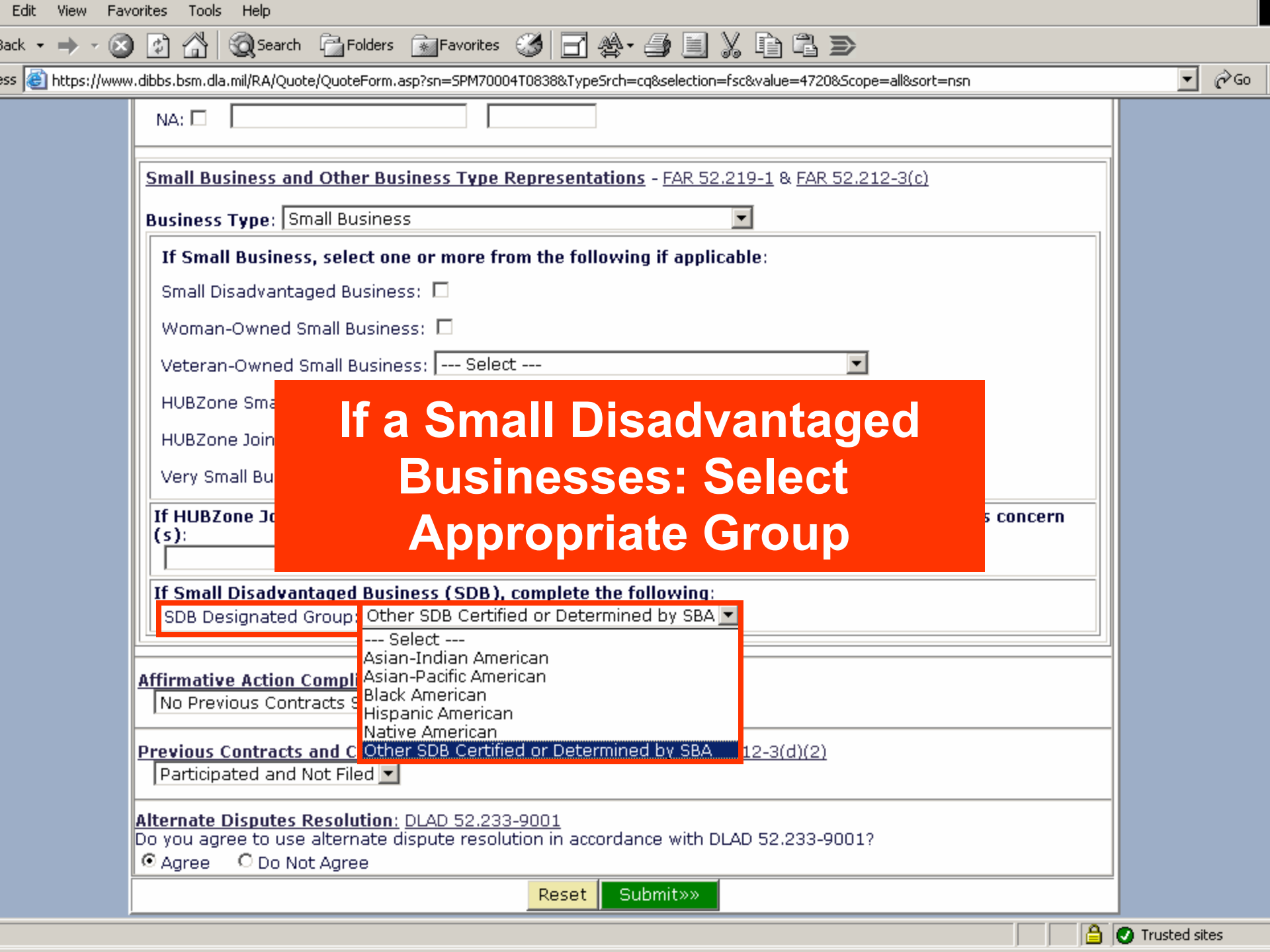

NA:

Small Business and Other Business Type Representations - [FAR 52.219-1](#) & [FAR 52.212-3\(c\)](#)

Business Type:

If Small Business, select one or more from the following if applicable:

Small Disadvantaged Business:

Woman-Owned Small Business:

Veteran-Owned Small Business:

HUBZone Small Business

HUBZone Joint Venture

Very Small Business

If a Small Disadvantaged Businesses: Select Appropriate Group

If HUBZone Joint Venture, select one or more from the following if applicable: **Small Business concern**

(s):

If Small Disadvantaged Business (SDB), complete the following:

SDB Designated Group:

- Select ---
- Asian-Indian American
- Asian-Pacific American
- Black American
- Hispanic American
- Native American
- Other SDB Certified or Determined by SBA

Affirmative Action Compliance

Previous Contracts and Certifications: [12-3\(d\)\(2\)](#)

Alternate Disputes Resolution: [DLAD 52.233-9001](#)

Do you agree to use alternate dispute resolution in accordance with DLAD 52.233-9001?

Agree Do Not Agree

NA: DSCC

Small Business and Other Business Type Representations - [FAR 52.219-1](#) & [FAR 52.212-3\(c\)](#)

Business Type:

If Small Business, select one or more from the following if applicable:

Small Disadvantaged Business:

Woman-Owned Small Business:

Veteran-Owned Small Business:

HUBZone Small Business:

HUBZone Joint Venture

Very Small Business:

If HUBZone Joint Venture (s):

If Small Disadvantaged SDB Designated Group



Affirmative Action Compliance [FAR 52.222-25](#) & [FAR 52.212-3\(d\)\(3\)](#)

-
-
-
-
-

[222-26](#) & [FAR 52.212-3\(d\)\(2\)](#)

Alternate Disputes Resolution: [DLAD 52.233-9001](#)

Do you agree to use alternate dispute resolution in accordance with DLAD 52.233-9001?

Agree Do Not Agree

NA: DSCC

Small Business and Other Business Type Representations - FAR 52.219-1 & FAR 52.212-3(c)

Business Type:

If Small Business, select one or more from the following if applicable:

Small Disadvantaged Business:

Woman-Owned Small Business:

Veteran-Owned Small Business:

HUBZone Small Business:

HUBZone Joint Venture that complies with 13 CFR Part 26:

Very Small Business:

If HUBZone Joint Venture, enter CAGE(s)/Name(s) of the participating HUBZone small business concern (s):

If Small Disadvantaged Business (SDB), complete the following:

SDB Designated Group:

Affirmative Action Compliance FAR

Previous Contracts and Compliance

Indicate if willing to use Alternate Disputes Resolution

Alternate Disputes Resolution: DLAD 52.233-9001

Do you agree to use alternate dispute resolution in accordance with DLAD 52.233-9001?

Agree Do Not Agree

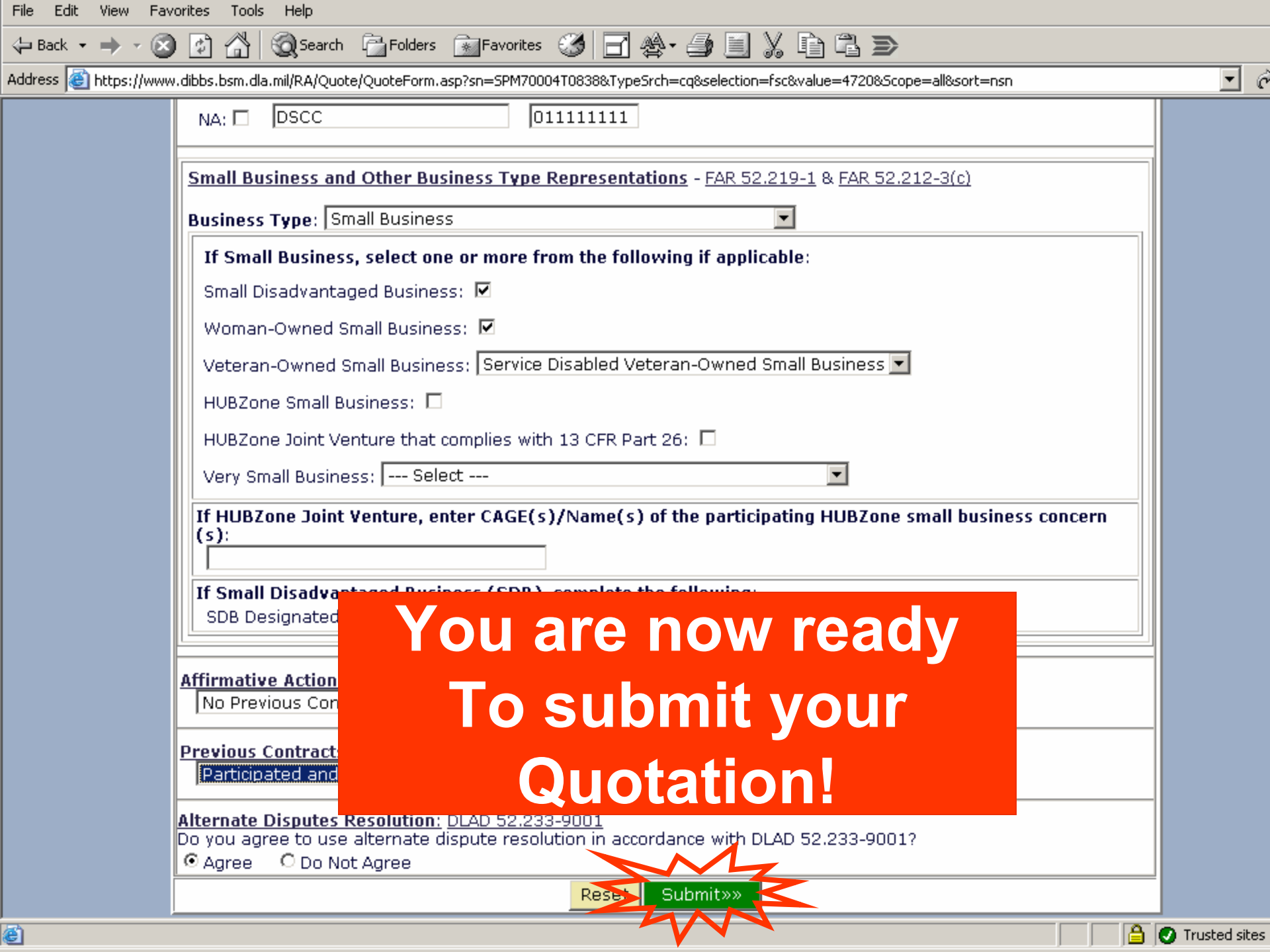

NA: DSCC

Small Business and Other Business Type Representations - [FAR 52.219-1](#) & [FAR 52.212-3\(c\)](#)

Business Type:

If Small Business, select one or more from the following if applicable:

Small Disadvantaged Business:

Woman-Owned Small Business:

Veteran-Owned Small Business:

HUBZone Small Business:

HUBZone Joint Venture that complies with 13 CFR Part 26:

Very Small Business:

If HUBZone Joint Venture, enter CAGE(s)/Name(s) of the participating HUBZone small business concern (s):

If Small Disadvantaged Business (SDB), complete the following:

SDB Designated

Affirmative Action

Previous Contract

Alternate Disputes Resolution: DLAD 52.233-9001

Do you agree to use alternate dispute resolution in accordance with DLAD 52.233-9001?

Agree Do Not Agree

**You are now ready
To submit your
Quotation!**

BSM-DIBBS Quote Summary

Display Date/Time: 2/6/2005 9:54:40 PM

Solicitation#:
SPM70004T0838

Log In CAGE:
DIBBS

Quoting For CAGE:
DIBBS

Buyer Code:
PMCMAB4

Header Data Area

· Bid Type: **BID WITHOUT EXCEPTION**

· Discount Terms: **1/2% 20 Days**

Vendor Quote#: **1234**

· Quote Valid for: **45 days.**

· Accept Packaging: **Yes**

· Federal Supply Schedule (FSS) / Basic Ordering Agreement (BOA) / Basic Purchase Agreement (BPA): **N/A**

· FOB Point: **Destination**

· Govt. Inspection Point: **Destination**

· SPI Process Proposed: **No**

**Review Quote
For Accuracy**

Price Data Area

· Pricing & Delivery

NSN/Part #: **4720000612080** NOMEN:HOSE,AIRDUCT

LINE # / PR #	QUANTITY	UI	UNIT PRICE	DELIVERY DAYS
0001 0010531227	2	EA	\$28.00000	30

Total Amount: \$56.00

· Minimum Order Quantity

Is a larger quantity obtainable at no additional total price due to a minimum order quantity?

NSN/PN: **4720000612080** **No**

· Quantity Variance

NSN/PN: **4720000612080** +0 -0 %

· Quantity Available for Immediate Shipment

Is there a quantity available for immediate shipment?

NSN/PN: **4720000612080** **No**

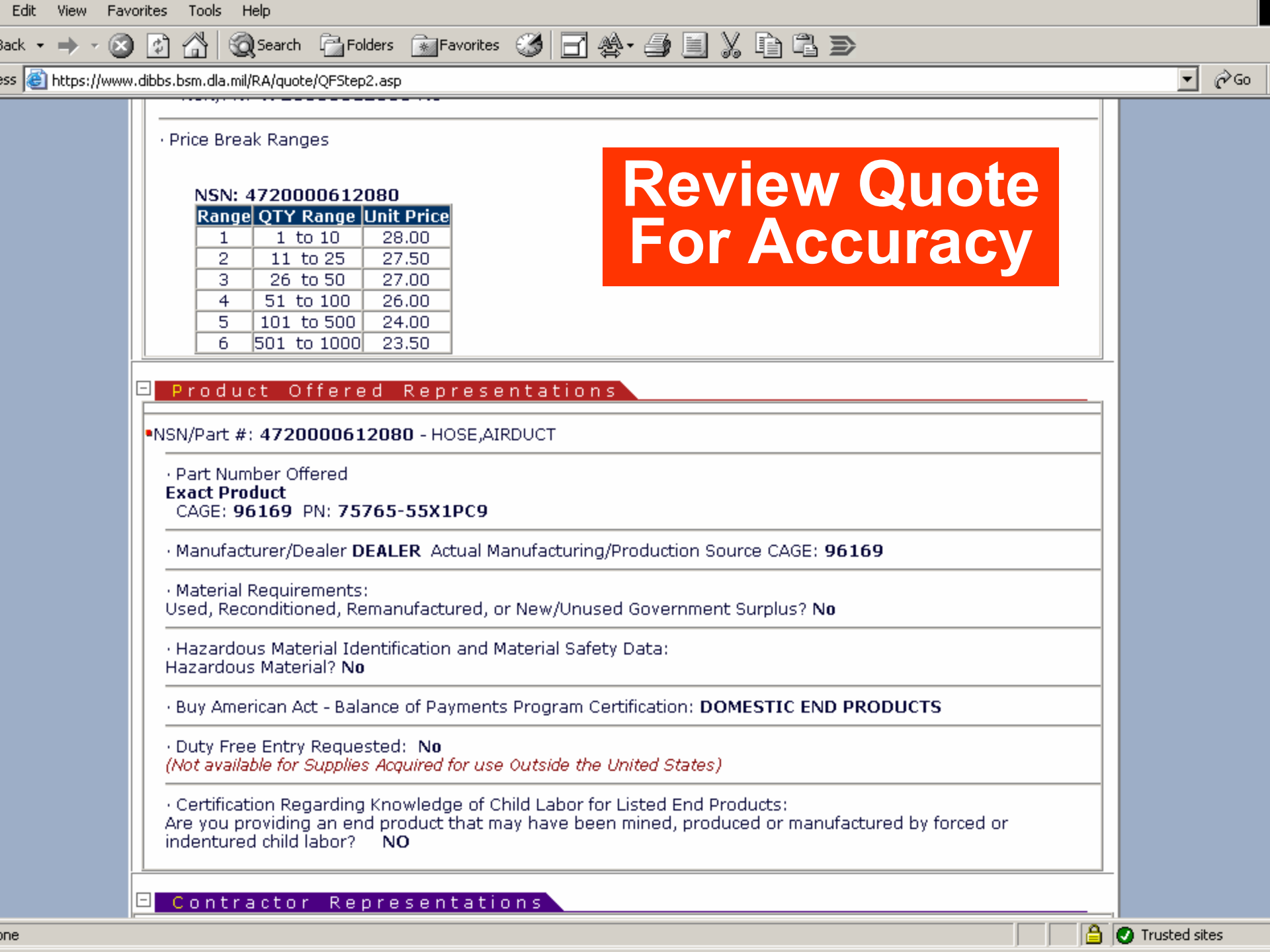

· Price Break Ranges

NSN: 4720000612080

Range	QTY Range	Unit Price
1	1 to 10	28.00
2	11 to 25	27.50
3	26 to 50	27.00
4	51 to 100	26.00
5	101 to 500	24.00
6	501 to 1000	23.50

**Review Quote
For Accuracy**

Product Offered Representations

· NSN/Part #: **4720000612080** - HOSE,AIRDUCT

· Part Number Offered

Exact Product

CAGE: **96169** PN: **75765-55X1PC9**

· Manufacturer/Dealer **DEALER** Actual Manufacturing/Production Source CAGE: **96169**

· Material Requirements:

Used, Reconditioned, Remanufactured, or New/Unused Government Surplus? **No**

· Hazardous Material Identification and Material Safety Data:

Hazardous Material? **No**

· Buy American Act - Balance of Payments Program Certification: **DOMESTIC END PRODUCTS**

· Duty Free Entry Requested: **No**

(Not available for Supplies Acquired for use Outside the United States)

· Certification Regarding Knowledge of Child Labor for Listed End Products:

Are you providing an end product that may have been mined, produced or manufactured by forced or indentured child labor? **NO**

Contractor Representations

Contractor Representations

· Taxpayer Identification Number (TIN) -
TIN: or Status: **Tin Applied For**

· Type of Organization: **Partnership**
· Common Parent - Name: **NA** TIN: **NA**

· Small Business and Other Business Type Representations:
· Type: **Small Business**
· **Small Disadvantaged Business** Ethnic Type: **Native American**
· Veteran Owned Business Status: **Service Disabled Veteran-Owned Small Business**
· **HUBZone Small Business**

· Affirmative Action Compliance **No Previous Contracts Subject to Requirements**

· Previous Contracts and Compliance Reports **Participated and Not Filed**

· Alternate Disputes Resolution:
Do you agree to use alternate dispute resolution in accordance with DLAD 52.233-9001? **Agree**

**Review Quote
For Accuracy**

Notice:

You have stated that the part number offered for NSN 4720000612080 is an 'exact product'. **Exact product means CAGE 96169 P/N 75765-55X1PC9: manufactured by, under the direction of, or under agreement with CAGE 96169.** Any product not meeting these criteria is considered an alternate product even though it may be manufactured in accordance with the drawings and/or specifications of CAGE 96169. (see DLAD 52.217-9002). To confirm the technical acceptability of your exact product quote, we may request documents (e.g., invoice, quote, agreement) to show traceability to CAGE 96169. Failure to provide adequate traceability upon request may result in the rejection of your quote as technically unacceptable. Any indication that you have misrepresented the product offered shall result in the Government considering rescission of any resultant contract and all other sanctions, contract penalties, and remedies established under any other law or regulation.

NOTE: It is possible for an item description to change between issuance of the solicitation and the resulting order. If an order is issued by the Government in response to this quotation that does not cite CAGE 96169 P/N 75765-55X1PC9, you should not commence performance but should promptly notify the administrative contracting officer of t

If Accurate

Contractor's Address:
**DIBBS TEST CAGE
3990 EAST BROAD STREET
COLUMBUS, OH UNITED STATES
43216-5000**

Reset Submit»»





Quote Successfully Submitted

Home Solicitations

Naviga

Location: Home » Solicitations » RFQs » **Quote Submission**

LOGGED ON ENHANCED OFF

[37] 02/06/2005 9:57:04 PM

Your Quote has been successfully submitted.

Solicitation #	Total	Quoting For CAGE	Quoter	Vendor Quote#	Quote Date/Time ET
SPM70004T0838	\$56.00	DIBBS	DSCC Small Business - Eleanor Holland	1234	2/6/2005 9:57:04 PM

- ▶ [New RFQ Search](#)
- ▶ [View Today's Submitted Quotes](#)
- ▶ [Search Submitted Quotes](#)

▶ Fast Trak Quoting

If you know your solicitation number, you may enter it here and go directly to step one of the quote form by passing the RFQ search.

Solicitation #:

(Enter without dashes or spaces)

Let's Look at a Solicitation with Drawings

Click on the Solicitation # to view the RFQ & NSN/Part No. to view additional info.

#	NSN/Part No. Nomenclature	Bidset/ Drawings	Spec/ Std	Solicitation #	Auction Status	PR # PR QTY	Issue	Return By
1	4720-01-124-1059 HOSE		None	SPM700-05-T-0245		0010776265 QTY: 226	10/6/2004	11/01/2004
2	4720-01-084-7561 HOSE ASSEMBLY	Avail	None	SPM760-05-Q-0219 Revised: 12/01/2004		0010891646 QTY: 2	12/1/2004	12/15/2004
3	4720-00-918-0714 HOSE ASSEMBLY, METALLI QPL		None	SPM760-05-Q-0216		0010850505 QTY: 5	12/1/2004	12/15/2004
4	4720-01-303-4133 HOSE ASSEMBLY, METALLI QPL	Avail	None	SPM760-05-Q-0293		0010772803 QTY: 3	1/11/2005	01/25/2005
5	4720-01-079-0264 HOSE ASSEMBLY, NONMETA	Avail	None	SPM760-05-Q-0260		0010891644 QTY: 2	12/28/2004	01/11/2005
6	4720-01-226-8466 HOSE ASSEMBLY, NONMETA	Avail	None	SPM760-05-Q-0308		0010964965 QTY: 4	1/17/2005	01/24/2005

Before Opening a Drawing for the 1st time, Download a Viewer

• Main Page

▶ Requests

▶ Data Custodians

▶ POCs

• Viewers

▶ Documents

Bidset Package View

⚠ Cautionary Note: It is your responsibility to make sure that you obtain and use the drawings and revision levels that are called out in the solicitation. Discrepancies found in the bidset should be E-Mailed to: dbi-drawings@dsccl.dla.mil

Solicitation Data

Solicitation: **SPM76005Q0308** Issue: **1/17/2005** Closes: **1/24/2005** ICP: **DSCC** **BSM Item**

Files

NOTE: ONE ZIP FILE PER NSN AND DRAWING RESTRICTION TYPE WILL BE PROVIDED.

NSN	Unrestricted File	Restricted / Proprietary Files
4720-01-226-8466	Unrestricted NSN Drawing Package 12/29/2004 size: 633 KB	None

Drawings

[View Available Unrestricted Drawings in Sheet Mode](#) 

NSN: **4720-01-226-8466**

CAGE	Drawing #	REV	DOC Type	Title	DISTRB	Status
77272	A15H3351	E	SC	HOSE ASSEMBLY	A	Available 



Welcome to the JEDMICS ToolSet Web Site.

SECURITY WARNING

This is a Department of Defense Computer System . This computer system, including all related equipment, networks and network devices (specifically including internet access), are provided only for authorized U.S. government use. DOD computer systems may be monitored for all lawful purposes, including to ensure that their use is authorized, for management of the system, to facilitate protection against unauthorized access, and to verify security procedures, survivability and operational security. Monitoring includes active attacks by authorized DOD entities to test or verify the security of this system. During monitoring information may be examined, recorded, copied and used for authorized purposes. All information, including personal information, placed on or sent over this system may be monitored.

Use of this DOD Computer System, authorized or unauthorized, constitutes consent to monitoring of this system. Unauthorized use may subject you to criminal prosecution. Evidence of unauthorized use collected during monitoring may be used for administrative, criminal or other adverse action. **Use of this system, indicated by continuing beyond this page, constitutes consent to monitoring for these purposes.**

Unauthorized access to this United States Government computer system is prohibited by Title 18, United States Code, Section 1030, Fraud and Related Activity in Connection with Computers.

ToolSet products are Government Owned, Government Furnished software products provided to Government and contractor organizations for the purpose of conducting official Government business. The JEDMICS ToolSet products are not public domain software.

website is to provide a centralized source for distribution and support of a common set of software for Government agencies, and their contractors, to access digitized engineering drawings and related data.





- Main Page
- ▶ Requests
- ▶ Data Custodians
- ▶ POCs
- Viewers
- ▶ Documents

Viewer Programs

There are many files available for download from the this website. These files exist in a number of different file some of which require the use of separate "viewer" programs. Links to download several viewer programs are below.

 Adobe® Portable Document Format (PDF)
<http://www.adobe.com/products/acrobat/readstep.html> 

 AutoCAD® Computer Aided Design (DWG, DWF, and DXF™)
<http://usa.autodesk.com/adsk/servlet/index?siteID=123112&id=837403> 

 Microsoft Word (DOC)
16-bit version: <http://office.microsoft.com/downloads/9798/wdvw9716.aspx> 

 Microsoft Excel (XLS)
<http://office.microsoft.com/downloads/2000/xlview>

 CALS Raster (C4) (MIL-PRF-28002C)
Image R: <http://jtshelp.redstone.army.mil> 

 Compressed Archive (ZIP)
<http://www.pkware.com> 
<http://www.winzip.com> 

Select
CALS Raster
& follow steps

This site does not officially recommend nor provide technical support or guidance for any image viewer software or issues related to these products must be addressed directly to the product vendor.

Unrestricted Bidset Sheet Level View

Cautionary Note: It is your responsibility to make sure that you obtain and use the drawings and revision levels that are called out in the solicitation. Discrepancies found in the bidset should be E-Mailed to: dbi-drawings@dsccl.dla.mil

Solicitation Data

Solicitation: **SPM70005T1737** Issue: **11/29/2004** Closes: **12/14/2004** ICP: **DSCC BSM ITEM**

Click on the Status or C4 icon to display the sheet.

NSN: **4720-01-079-0256**

[Download UnRestricted NSN Drawing Package](#) Size: 798 KB dtd: 12/1/2004

CAGE: **10001** DRW#: **3177651** REV: **A** DOC TYPE: **CN**

Title: **HOSE ASSY, FLEXIBLE** Sheets: 0001

Sheet #	Frame #	File Size	DOC Type	Rights	Status
0001	0001	251 KB	CN	U	Available Download 



CAGE: **10001** DRW#: **3177651** REV: **A** DOC TYPE: **DD**

Title: **HOSE ASSY, FLEXIBLE** Sheets: 0001

Sheet #	Frame #	File Size	DOC Type	Rights	Status
0001	0001	130 KB	DD	U	Available Download 

CAGE: **10001** DRW#: **3177651-8** REV: **A** DOC TYPE: **PL**

Title: **HOSE ASSY, FLEX** Sheets: 0001

Sheet #	Frame #	File Size	DOC Type	Rights	Status
0001	0001	55 KB	PL	U	Available Download 

CAGE: **10001** DRW#: **3178136** REV: **C** DOC TYPE: **CN**

Title: **HOSE ASSEMBLY** Sheets: 0001

Sheet #	Frame #	File Size	DOC Type	Rights	Status
0001	0001	180 KB	CN	U	Available Download 

CAGE: **10001** DRW#: **3178136** REV: **C** DOC TYPE: **VC**

Title: **HOSE ASSEMBLY** Sheets: 0005

Sheet #	Frame #	File Size	DOC Type	Rights	Status
0001	0001				

Once viewer is installed, click "Available Download"

HUGHES

FSCM NO. 1000/0000

ENGINEERING ORDER
 DOCUMENT CHANGE NOTICE

CLASS I COMPATIBILITY CLASS II
 CLASS II RECORD CORRECTION

CHANGE IDENT NO.

80017

SHEET 1 OF 1

FILE HOSE ASSY, FLEXIBLE				PROJECT SID		ECORN, ETC.		DRAWING NO. 3177651		REV. NO. A	NO. 1		
TYPE OF CHANGE <input type="checkbox"/> MANDATORY <input checked="" type="checkbox"/> MANUFACTURING CONVENIENCE <input type="checkbox"/> MANUFACTURING OPTION													
CONTROL ITEM				CONFIGURATION ITEM				PREPARED BY <i>Rosenbrock</i>	ORG CODE 11773-40	DATE 12-26-78	APPROVED <i>J. J. Hoover</i>	ORG CODE 11773-40	DATE 12-26-78
DRAWING NO.	EFFECTIVITY	DRAWING NO.	EFFECTIVITY	CHECKED BY <i>E. H. Hays</i>	DATE 12-26-78	DATE 12-26-78	DATE 12-26-78	DATE 12-26-78	DATE 12-26-78	DATE 12-26-78	DATE 12-26-78	DATE 12-26-78	
3177911	NC												
3177975	NC												
3177984	NC												
3177950	NC												
DISPOSITION OF ITEMS <input type="checkbox"/> ITEMS COMPOSED <input checked="" type="checkbox"/> USE <input type="checkbox"/> REMOVE AS FOLLOWS. SEE REMARK INSTRUCTIONS													

REASON AND DESCRIPTION - SEE BELOW FOR P/L CHANGES

REASON: CHANGE LOCATION MARKING BAND

ZONE 6C

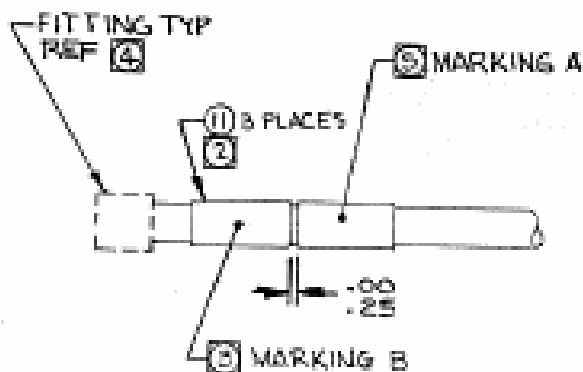

IS

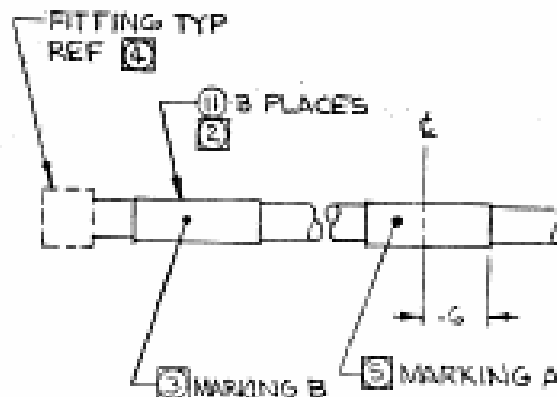

WAS

STANDARD
G S G
RELEASE

DISTRIBUTION STATEMENT A:
"APPROVED FOR PUBLIC RELEASE;
DISTRIBUTION IS UNLIMITED."

ITEM NO.	LINE NO.	ADD	DELETE	QTY REQ.	UNIT OF MEAS.	MFG CODE IDENT NO.	PART OR IDENT NUMBER	DESCRIPTION	SPECIFICATION OR REFERENCE	FROM REF. DESIGNATION	THRU	WEIGHT IN LBS.	P/L	ZONE

The DLA capability to supply include search and information

The BSM Supply Class BSM during information

Solicitations Over \$100,000 Requests for Proposals (RFPs)

Registered User Log In



number (NSN) or Federal items and users into table. Additional

Help

- Help
 - [Frequently Asked Questions ~ FAQ](#)
 - [DIBBS On-Line Quoting Help](#)
 - [Batch Quoting Help](#)
- Contact Us

Solicitations

- Requests for Quotation (RFQ)
 - [RFQ Auctions](#)
 - [Batch Quoting](#)
 - [Submitted Quote Searching](#)
- Requests for Proposal (RFP) / Invitation For Bid (IFB)**
- Other DLA Opportunities

References

- [BSM Program NSN/FSC Query Database](#)
- [All FSCs managed by DLA](#)
- [Master Solicitation Documents](#)
- [Regulation Extracts used for DIBBS quoting](#)

Vendor Registration

- Vendor Registration
- Registration Guidelines

Awards

- Awards
- Other DLA Awards
- Subsistence Blanket Purchase Agreements (BPAs)

Technical Data

- [DLA-BSM Bidset Interface](#)
- [DoD Specifications and Standards](#)



Search for RFPs By Search Category or View All

RFP/IFB Database

Search Categories:

FSC/National Stock Number Solicitation Number
 Nomenclature Buyer Code
 Issue Date (mm/dd/yyyy) Close Date (mm/dd/yyyy)

Search Value(s):

Records per page: 10 25 50 75

Sorted by:

Solicitation Issue Date
 NSN Return By Date
 Nomenclature

Then by:

Solicitation Issue Date
 NSN Return By Date
 Nomenclature

Show Only Items with Bid Sets

[VIEW ALL RFP/IFB](#)



Location: Home » Solicitations » RFP/IFBs » **Search Results**

LOGGED

[New RFP/IFB Search](#) 🔑

RFP/IFBs for **Solicitation #** Like * sorted by NSN.

Records 1 thru 4 of 4 Records.

Page: 1 of 1

Click on the Solicitation # to view the RFP/IFB Package.

#	NSN/ Nomenclature	Bidset/ Drawings	Solicitation #	Issued	Closes
1	1560-00-176-1250 TANK,FUEL,AIRCRAFT		SPM406-05-R-0002	1/19/2005	
2	8910-00-SUB-SIST Dairy Foods and Egg		SPM300-05-R-0316	1/31/2005	2/18/2005
3	8920-00-SUB-SIST Bakery and Cereal Prods		SPM300-05-R-0307	1/10/2005	2/9/2005
4	8975-00-PRM-VEND PRIMEVENDOR, MULTIPLE FSC		SPM300-05-R-0305	1/7/2005	2/20/2005

**Select
solicitation
to review**

Page: 1 of 1

[New RFP/IFB Search](#) 🔑



Location: Home » Solicitations » RFP/IFBs » **SPM406-05-R-0002**

LOGGED OFF ENHANCED C

[New RFP/IFB Search](#)

[37] 02/06/2005 11:10:0

Solicitation Package: SPM40605R0002PKG.zip	Issue Date: 01/18/2005	Close Date: 02/11/2005	NSN: 1560-00-176-1250	Nomenclature: TANK,FUEL,AIRCRAFT	Buyer Code: ROF14
--	----------------------------------	----------------------------------	---------------------------------	--	-----------------------------

Click here to open the solicitation

Solicitation:
[SPM40605R0002.pdf](#)

Attachment(s):

Attachment(s):
[SPM40605R00020001.pdf](#)

Attachment(s):

Fed BizOpps Synopsis: Not Available at this time.

Note: Offers/Sealed Bids for RFPs/IFBs shall be submitted in accordance with the instructions in Block 9 of the solicitation.



Would you like to be notified of any/all Amendments to this Solicitation?

YES

NO

If Yes, then please complete the following:

Required Email:

Company Name:

Address:

City:

State:

Zip Code:

CAGE Code:

[Submit](#)

[Clear Form](#)

Complete and submit to be notified of changes to the RFP

If you just want to look at the RFP, check "NO" and submit

**INFORMATION TO OFFERORS OR QUOTERS
SECTION A - COVER SHEET**

*Form Approved
GSA FPMR (41 CFR) 101-11.6
Expires 06/30, 2004*

The public reporting burden for this collection of information is estimated to average 30 minutes per response, including reviewing instructions, searching existing data sources, gathering and reviewing the data needed, and completing and reviewing the collection of information. Send comments regarding this burden estimate or any other aspect of this collection of information, including suggestions for reducing the burden, to Department of Defense, Washington Headquarters Service, Directorate for Information Operations and Reports (DOD/IGR), 1215 Jefferson Davis Highway, Suite 1204, Arlington, VA 22202-4302. Responses should be sent to the appropriate office of the Department of Defense. Do not send responses to this collection of information unless it displays a currently valid OMB control number.

PLEASE DO NOT RETURN YOUR FORM TO THE ABOVE ADDRESS. RETURN COMPLETED FORM TO THE ADDRESS IN BLOCK 4 BELOW.

1. SOLICITATION NUMBER SFM406-05-B-0001		2. (X one) <input type="checkbox"/> a. INVITATION FOR BIDDING <input checked="" type="checkbox"/> b. REQUEST FOR PROPOSAL (RFP) <input type="checkbox"/> c. REQUEST FOR QUOTATION (RFQ)	3. DATE/TIME RESPONSE DUE 2004 DEC 15 1:00 PM
INSTRUCTIONS			
<p>Note: The provision entitled "Required Contract Completion Registration" applies to most solicitations.</p> <p>1. If you are not submitting a response, RETURN BY AIRMAIL BY REGISTERED MAIL AND RETURN BY AIR MAIL TO THE ADDRESS IN BLOCK 4 ABOVE. A different return address is indicated in Block 7.</p> <p>2. Offerors or quoters must include full, accurate, and complete information in their responses as required by this solicitation (including attachments). "Fill-ins" are provided on Standard Form 101, Standard Form 102, and other acquisition documents. Examine the order administration carefully. The penalty for making false statements is provided in 48 CFR, 101-11.6.</p> <p>3. Offerors or quoters must plainly mark their responses with the Solicitation Number and the date and local time for bid opening or receipt of proposals that is in the solicitation document.</p> <p>4. Information regarding the types of responses to be submitted in the solicitation of this acquisition is located within the "Instructions," "Bid Documents," and "Attachments of Bid" or Instructions to Offerors - Competitive Acquisition.</p>			
4. MAILING OFFICE (Complete mailing address, including Zip Code) Defense Supply Center Richmond ATTN: DSCR Procurement 3000 Jefferson Davis Highway Richmond, Virginia 23297-9778		5. ITEM TO BE PURCHASED (Item description) TANK,FUEL,AIRCRAFT	
6. PROCUREMENT INFORMATION (X and complete as applicable)			
X <input type="checkbox"/> a. THIS PROCUREMENT IS UNRESTRICTED			
<input type="checkbox"/> b. THIS PROCUREMENT IS SET-ASIDE FOR SMALL BUSINESS. THE APPLICABLE NAICS CODE IS:			
<input type="checkbox"/> c. THIS PROCUREMENT IS SET-ASIDE FOR 8(a) CONCERNS. THE APPLICABLE NAICS CODE IS:			
<input type="checkbox"/> d. THIS PROCUREMENT IS RESTRICTED TO FIRMS CLASSIFIED UNDER SECTION 8(a) OF THE SMALL BUSINESS ACT.			
7. ALTERNATE TELEPHONE			
8. POINT OF CONTACT FOR INFORMATION			
a. NAME (Last, First, Middle Initial) Annika Crawford, FA80914		b. ADDRESS (Include Zip Code) Defense Supply Center Richmond ATTN: DSCR Procurement 3000 Jefferson Davis Highway Richmond, Virginia 23297	
c. TEL. OFFICE NUMBER (Include Area Code and Extension) 804-474-6718		d. E-MAIL ADDRESS annika.crawford@gsa.mil	
9. REASONS FOR NO RESPONSE (X all that apply)			
<input type="checkbox"/> a. I'M NOT INTERESTED IN THIS ACQUISITION		<input type="checkbox"/> d. DO NOT REGULARLY MANUFACTURE OR SELL THE TYPE OF ITEMS INVOLVED	
<input type="checkbox"/> b. UNABLE TO PRINT/REUSE ITEMS		<input type="checkbox"/> e. OTHER (Specify)	
<input type="checkbox"/> c. CANNOT MEET DELIVERY REQUIREMENT			
10. MAILING LIST INFORMATION (X one)			
<input type="checkbox"/> YES <input type="checkbox"/> NO <input type="checkbox"/> DO NOT DESIRE TO BE RETAINED ON THE MAILING LIST FOR FUTURE PROCUREMENT OF THE TYPE ABOVE.			
11a. COMPANY NAME		b. ADDRESS (Include Zip Code)	
a. ACTION OFFICER (1) Typed or Printed Name (Last, First, Middle Initial)		(2) Title	(3) Signature
			(4) DATE, MONTH, YEAR



DEFENSE LOGISTICS AGENCY

Www.DIBBS.BSM.DLA.MIL

BUSINESS SYSTEMS MODERNIZATION - DLA INTERNET BID BOARD SYSTEM

Home

Solicitations

RFQs

RFP/IFBs

Tech Data

Downloads

Awards

Navigation: Navig

Choose Search

Location: Home

LOGGED OFF ENHANCE

[37] 02/06/2005 11:0

The DLA-BSM capability to search for supply included in search and view information related to

The BSM NSN Supply Class (FSC) BSM during regular information is av

Other DLA Opportunities (More RFPs)

the
ms of
ers to
ement



lock Number (NSN) or Federal
additional items and users into
es available. Additional

Help

- [Help](#)
 - [Frequently Asked Questions ~ FAQ](#)
 - [DIBBS On-Line Quoting Help](#)
 - [Batch Quoting Help](#)
- [Contact Us](#)

Solicitations

- [Requests for Quotation \(RFQ\)](#)
 - [RFQ Auctions](#)
 - [Batch Quoting](#)
 - [Submitted Quote Searching](#)
- [Requests for Proposal \(RFP \) / Invitation For Bid \(IFB\)](#)
- [Other DLA Opportunities](#)

References

- [BSM Program NSN/FSC Query Database](#)
- [All FSCs managed by DLA](#)
- [Master Solicitation Documents](#)

Vendor Registration

- [Vendor Registration](#)
- [Registration Guidelines](#)

Awards

- [Awards](#)
- [Other DLA Awards](#)
- [Subsistence Blanket Purchase Agreements \(BPAs\)](#)

Technical Data

- [DLA-BSM Bidset Interface](#)
- [DoD Specifications and Standards](#)



Corporate Contract/Tailored Support Solicitations

[CCT Home Page](#) | [Solicitations](#) | [Awarded CORP Contracts](#)

RFPs with Multiple NSNs

If you are interested in the solicitation number in the below table.

the solicitation number in the

Solicitations are available. Hard copies of the solicitation are not available.

te. Hard copies of the

2/6/2005 11:21:29 PM

Click on the Solicitation/Project# to review the project.

Open Items: 12

Solicitation/Project#	Issued Date	Closing Date	Project Name	Description	# NSNs
SP0750-05-R-3485	1/7/2005	2/7/2005	Stewart Stevenson	Multiple NSN	13
SP0750-05-R-3517	12/30/2004	2/18/2005	WHEELER SBA	TRANSPORTATION EQUIPMENT	18
SP0750-05-R-3518	1/24/2005	2/24/2005	Multiple NSN LTC/LD4315017	Motor Vehicle Parts	44
SP0900-05-R-X390	1/6/2005	2/24/2005	L3 Communications/Power Paragon (04801)	Sole Source LTC	25
SP0750-05-R-3496	1/25/2005	2/25/2005	Unrestricted - Multiple NSN's	Vehicular Equipment	14
SP0750-05-R-3524	1/25/2005	2/25/2005	Unrestricted - Multiple NSN - LD4315009	Vehicular Equipment	6
SP0700-05-R-4300	1/20/2005	3/10/2005	Meritor Non-Price Listed Items	Various Meritor Items	126
SP0750-05-R-3558	2/11/2005	3/11/2005	LD4315003	MULTIPLE NSNs	10
SP0750-05-R-3511	2/14/2005	3/16/2005	Multiple NSNs-Unrestricted Procurement	Multiple NSNs-Unrestricted Procurement	25

Site search: [Go](#)

[DSCC Home](#)

[Buying from DSCC](#)

[Selling to DSCC](#)

[Detailed Searches](#)

[Library](#)

[News](#)

[Links](#)

[Contact Us](#)

POC

Closing Date: 2/25/2005

- Multiple NSN's

Description: Vehicular Equipment

DSCC Point of Contact
Mickey, Margaret C., Margaret.Mickey@dla.mil
Phone: (614) 692-8868 Fax: (614) 692-3214
Office: DSCC-LXA

Text Files	Project HTML Files
summary.txt	Index.html
nsn.txt	nsn.html
partnumbers.txt	partnumbers.html
	noms.html

More files posted here:
[DIBBS RFP Area](#)

NOTE: Items with AMSC codings of 'B', 'G' or 'T' must be provided in accordance with the applicable Drawing(s) and/or Specifications in the Item Descriptions. CAGE Codes and Part Numbers cited under these categories are for reference only and are not intended for the purpose of requesting Part Number offers.

List of NSNs included in the solicitation

Page 1
Total P

#	Na			AMSC	SOS
1	2510-01-374-2612	None	BODY,CARGO TRUCK	1	H S9C
2	2510-01-375-1900	None	BODY,CARGO TRUCK	1	H S9C
3	2510-01-375-6294	None	HINGE,DOOR VEHICULA	1	C S9C
4	2510-01-375-7117	None	HINGE,DOOR VEHICULA	1	C S9C
5	2540-01-376-3999	Avail	...		
6	2540-01-384-0975	None	VISOR,SUN,VEHICLE	1	H S9C
7	2540-01-460-7988	None	FRAME,SEAT,VEHICULA	3	H S9C
8	2540-01-460-8057	None	ADJUSTER,VEHICULAR	3	H S9C
9	2540-01-498-4343	Avail	SEAT,VEHICULAR	3	H S9C
10	2590-01-388-4717	None	BRACKET,VEHICULAR C	1	C S9C
11	2590-01-443-2208	None	BRACKET,VEHICULAR C	3	C S9C
12	2920-01-487-3587	Avail	...		
13	4820-01-374-2819	None	SLEEVE,DIRECTIONAL	3	H S9C
14	4820-01-475-4873	None	VALVE,PNEUMATIC TAN	1	H S9C

Some may have bid packages

Project: SP075005R3496 Posted:1/10/2005 11:10:23 AM
NSN: 2510013742612 SOS: S9C
AMSC: H QCC: EAA
ITEM DESCRIPTION: POTENTIALLY HAZARDOUS, SEE REPRESENTATION
CRITICAL APPLICATION ITEM

BODY,CARGO TRUCK

THE INTERNATIONAL ORGANIZATION FOR
STANDARDIZATION (ISO) 9002 OR A "TAILORED"
PROGRAM MEETING THE FOLLOWING ISO 9002

PARAGRAPHS APPLIES:

4.5, DOCUMENT CONTROL: LIMITED TO INSPECTION
AND TESTING AS WELL AS APPLICABLE DRAWINGS,
SPECIFICATIONS AND INSTRUCTIONS REQUIRED BY
CONTRACT

4.6, PURCHASING: 4.6.1 AND LIMITED TO 4.6.2 A)
AND 4.6.4.2, ALL OTHER PARTS
ARE HEREBY DELETED

4.7, CUSTOMER-SUPPLIED PRODU

4.8, PRODUCT IDENTIFICATION

4.10, INSPECTION & TESTING:

4.11, INSPECTION, MEASURING

4.12, INSPECTION AND TEST ST

4.13, CONTROL OF NONCONFORMI

4.14, CORRECTIVE AND PREVENT

PARAGRAPH 4.14.3 APPLY TO PR

4.16, QUALITY RECORDS:

FAR CLAUSE 52.246-11 APPLIE

**This one is a Code
& Part Numbered
item with 2 sources
(no bid package
available)**

Approved Sources

CAGE	Part Number
OFW39	12378482
19207	12378482



Doing Business with DSCC and DLA



Where Do I Go For More Help and Information?



DSCC SMALL BUSINESS TEAM

1-800-262-3272 OR
COMMERCIAL 614-692-3541



NAME email address	PROGRAM	PHONE 614-692-XXXX
Eleanor Holland eleanor.holland@dla.mil	Director, DSCC Small Business Office	- 3735
Will Chavez william.chavez@dla.mil	Small Disadvantaged Business and 8(a) Programs	- 1288
Vikki Hawthorne vikki.hawthorne@dla.mil	Outreach and Woman Owned SDB/8(a) Program Support	- 4864
Rebecca Parks rebecca.parks@dla.mil	HUBZone	- 3510
Tom Pfenning thomas.pfenning@dla.mil	Javits/Wagner/O'Day Workshops (Blind & Severely Handicapped)	- 1494
Dwight deWeaver dwight.deweaver@dla.mil	Service Disabled Veteran Owned	- 7935



Procurement Technical Assistance Centers (PTACs)



What are PTACs???

Government funded local resources available across the country providing assistance in marketing your products and services to Federal, state and local governments

PTAC Goals:

- Help small businesses be competitive
- Explain the complexities of Government procurement
- Encourage economic development through job retention and creation
- Build strong contractors through targeted training and one-on-one assistance

<http://www.dla.mil/db/procurem.htm>



Monthly Free Training

DEFENSE SUPPLY CENTER COLUMBUS



TTraining

Knowledge

Opportunities
Free Seminars

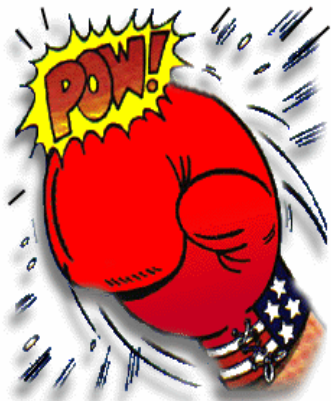

Doing Business With DSCC:

- Getting Started
- Assistance in your area (PTACs)
- Small Business Programs
- Quoting on DLA BSM DIBBS
- Hands-on computer lab time
- Alternate Offers – how to get approved
- Understanding quality requirements
- Packaging – what the government wants
- How to get Drawings and Bid-sets
- DoD EMail – Be on-line for our Customers
- Payment Processing
- Freedom of Information (FOIA)
- Meet Buyers and Technicians one-on-one

SEPTEMBER 20-21, 2005

OCTOBER 18-19, 2005

NOVEMBER 15-16, 2005

**Seating is limited – make reservation on-line at:
<http://www.dsccl.dla.mil/News/events/tko/>**

**Thank you for your
Time and Attention**

**Leaving you with a
Final Thought on how important
your contribution will be**



**Let's work together
to bring them home safely!**